

## 1 Introduction

The JST X27 Miniature stepper motor series are developed as an indicator drive for dashboard instrumentation and other indicator equipment. The inherent properties of torque, current consumption, robust construction, etc. extend its use also to a number of other applications.

The motor can operate directly from a numerical, i.e. digital, driving signal to move and position a pointer to visualize any parameter required. A fine analogue representation of its value and its changes is made without the need for a digital to analogue conversion.

The stepper motor has an accurate and repetitive movement and can operate directly with digital signals from a micro-controller or an ASIC. The JST X27 stepper motor has an electro-magnetic circuit and a gear train with 1/180 reduction to generate the minute indicator movement. It is produced with the advanced wide range technologies of Juken Technology Group.

Each half revolution of the rotor, defined as a full step, is converted to a one degree rotation of the pointer shaft. The full step itself can be divided into three partial steps, i.e. a 360 degree rotation of the pointer shaft consists of 1080 partial steps. Full steps can be carried out up to 600 Hz resulting in a 600 °/s angular speed. Such characteristics allow a large dynamic range for indicator applications.

The construction is simple and robust without concessions to versatility or longevity. The high quality of the assembly process and material employed grant an excellent lifetime and liability of the product.

### 1.1 Summary of features

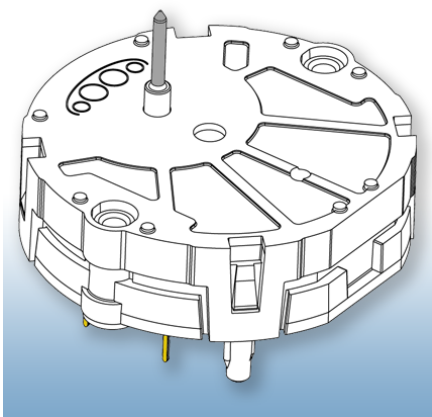

- 1/3° resolution per step
- low current consumption
- small dimensions: Ø 30 x 9 mm
- can be directly driven by a micro-controller
- large temperature range: -40° C ÷ 105° C
- high rotation speed up to 600 °/s
- qualified for automotive applications

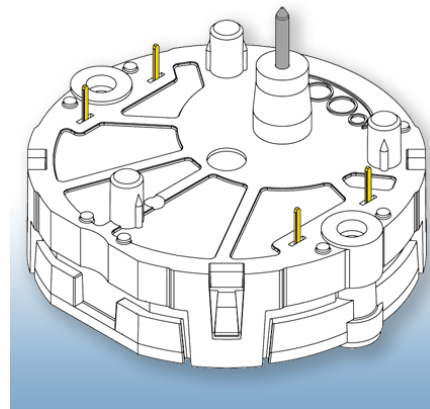
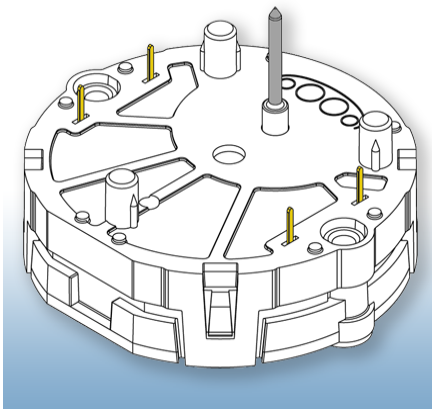

## 2 Functional description

The JST X27 is a stepper motor and the rotational movement is generated by an electro-magnetic circuit. The circuit is composed with 2 coils, a stator and a rotor with a bipolar permanent magnet. With specific signals applied to the coils, a magnetic field is driven through the stator. This magnetic field orientate the rotor and generates a rotational movement, in steps. The shape and voltage of the signals applied to coils define the step dimension and position.

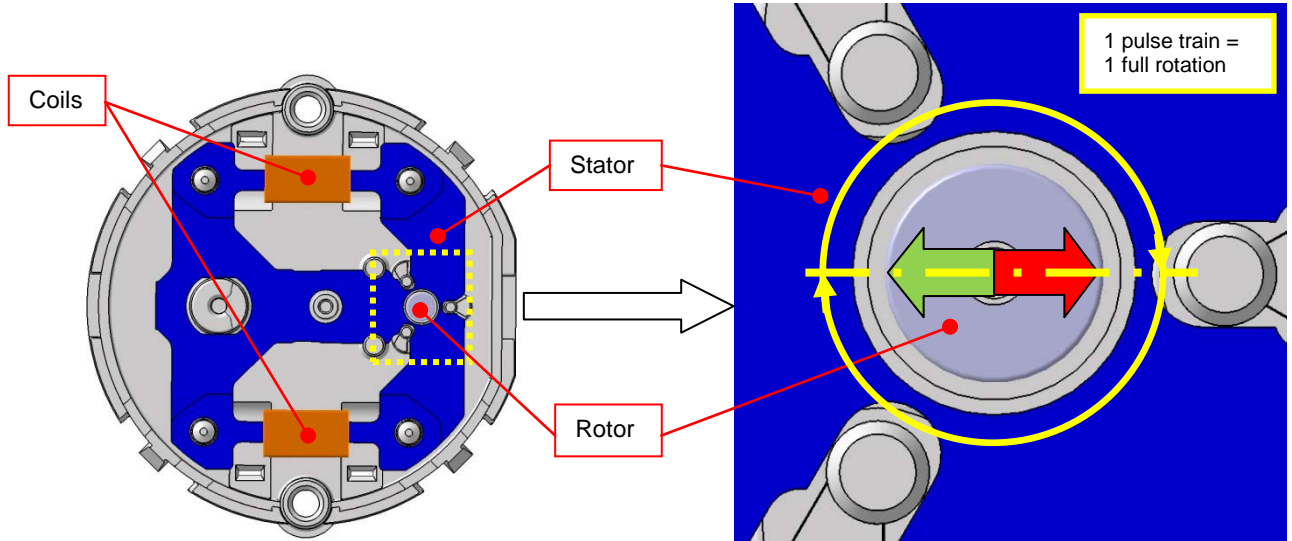

**Figure 1: Magnetic circuit**

The rotor of the motor makes one full rotation each pulse train (Figure 8). The steps are carried out according to the applied pulse sequence. The bit map shows the logic levels at the motor contacts 1 to 4 (Figure 2) and the corresponding coil voltage pulses.

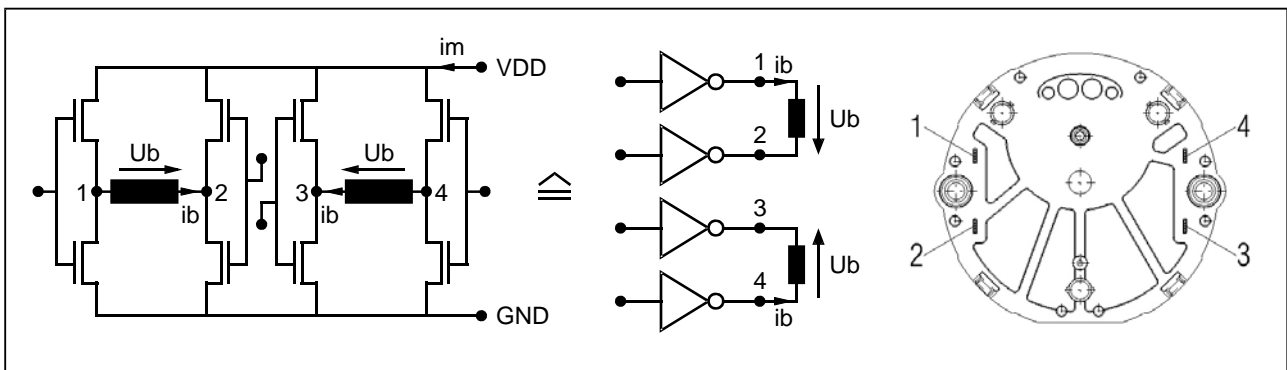

**Figure 2: X27 stepper motor contacts**

The direction of rotation is determined by the bit map sequence chosen. The inversion of the rotation sense can be realized on each point of the sequence, by inverting the pulse train sequence. The start-stop speed  $\omega_{SS}$  is dependent on the mechanical load applied and has to be respected.

The driving diagram (Figure 8, bit pattern) shows how the M-S can be driven using standard logic components capable of supplying 20 mA output current at Vdd of 5 volts.

## 2.1 Start-Stop speed $\omega_{SS}$

We define a speed threshold called Start-Stop speed, formerly indicated as Start-Stop frequency  $f_{SS}$ , to characterize the dynamics of the stepper motor. Up to the Start-Stop speed  $\omega_{SS}$ , a full start and a full stop is possible without missing a driving step (i.e. failing to carry out). The dynamic behavior of the system is influenced by the inertia of the load. The  $\omega_{SS}$  of the stepper motor X27, loaded with an inertial mass of 200 gmm<sup>2</sup>, is approximately 250 °/s.

The following example shows how the  $\omega_{SS}$  of a motor can be calculated. Needed parameters are:

- $M_D$  torque on the shaft depending of the rotation speed (Figure 13)
- $J_{M-S}$  motor gear equivalent inertia
- $J_L$  load inertia
- $\omega_z$  shaft rotation speed [°/s]

The angular velocity is  $\omega$  [rd/s] :

$$1^\circ) \quad \omega = \omega_z \cdot \frac{\pi}{180}$$

The acceleration torque  $M_\alpha$  needed to move the total of inertial masses  $J_{M-S} + J_L = J$  with the angular acceleration  $\alpha$  :

$$2^\circ) \quad M_\alpha = J \cdot \alpha$$

Also to accelerate from zero to the applied rotation speed  $\omega_z$ , the acceleration torque  $M_\alpha$  is equal to the effective dynamic torque  $M_D$  at this rotation speed:

$$3^\circ) \quad M_\alpha = M_d$$

The value  $M_D$  is determined by the measurement of the motor. This is a typical characteristic of the motor. The acceleration torque  $M_\alpha$  must also be determined as a function of  $\omega_z$ . The angular acceleration  $\alpha$  is:

$$4^\circ) \quad \alpha = \frac{\omega}{t_\alpha} = \omega \cdot \omega_z$$

$$5^\circ) \quad M_\alpha = J \cdot (\omega_z)^2 \cdot \frac{\pi}{180}$$

The start-stop speed  $\omega_{SS}$  is given by the intersection of the plot of these two curves as shown in Figure 3. Below calculation of  $\omega_{SS}$  using a reference pointer load (norm mass indicator):

$J_{M-S}$	=	610	$10^{-9}$	kgm <sup>2</sup>
$J_L$	=	200	$10^{-9}$	kgm <sup>2</sup> ( reference pointer )
$J$	=	810	$10^{-9}$	kgm <sup>2</sup>
$M_{\alpha 100}$	=	0.141		mNm
$M_{\alpha 200}$	=	0.565		mNm
$M_{\alpha 300}$	=	1.272		mNm

Then, from Figure 3 =>  $\omega_{SS} = 258$  °/s

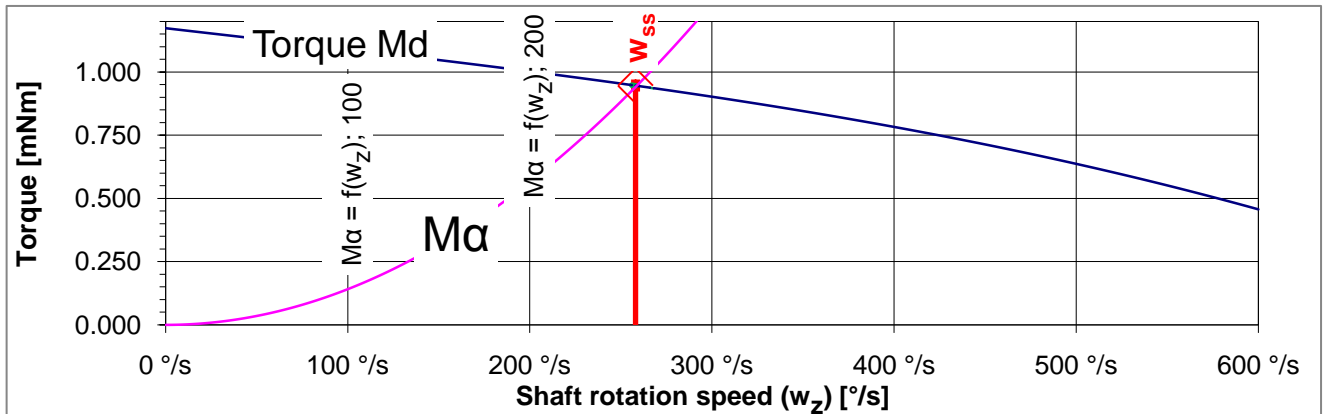

Figure 3: Graphic Determination of  $\omega_{SS}$

## 2.2 Acceleration to speeds > $\omega_{SS}$

In order to determine the maximum acceleration step  $\Delta\omega$ , the same type of calculation can be made as for  $\omega_{SS}$ . Instead of the angular velocity  $\omega$ , the difference in the angular velocity  $\Delta\omega$  is used for the calculation. The intersection of both curves is again used to determine the next higher speed  $\omega_{zi}$ .

$$6^\circ) \quad \Delta\omega = \omega_i - \omega_{i-1} = \frac{(\omega_{zi} - \omega_{zi-1}) \cdot \pi}{180} = \frac{\Delta\omega_{zi} \cdot \pi}{180}$$

Using the acceleration time

$$7^\circ) \quad t_a = \frac{1}{\alpha}$$

and the angular acceleration

$$8^\circ) \quad \alpha = \frac{\Delta\omega}{t_a} = \frac{(\omega_{zi} - \omega_{zi-1}) \cdot \omega_{zi} \cdot \pi}{180}$$

the acceleration torque  $M_\alpha$  needed to accelerate  $J$  to  $\omega_i$  can be calculated.

$$9^\circ) \quad M_\alpha = J \cdot \alpha = \frac{J \cdot (\omega_{zi} - \omega_{zi-1}) \cdot \omega_{zi} \cdot \pi}{180} = \frac{J \cdot \omega_{zi} \cdot \Delta\omega_{zi} \cdot \pi}{180}$$

The intersection of the curves gives the maximum driving speed or the shortest period which is needed to drive the motor with a maximum acceleration.

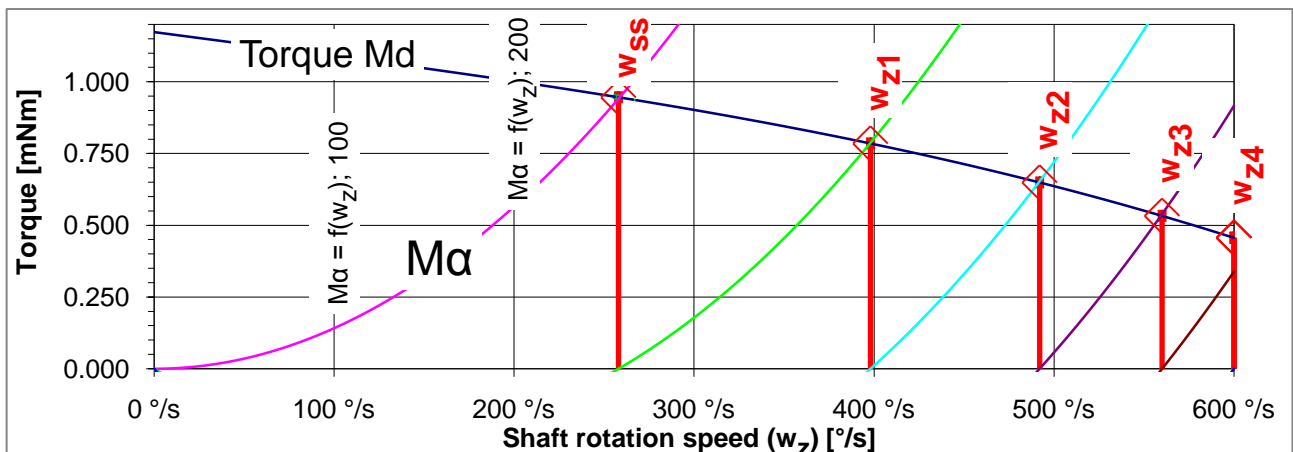

Figure 4: Determination of the acceleration steps

## 3 Installation and Dimensions

### 3.1 Motor Mounting

The Miniature Stepper Motors can be secured in place by a variety of methods. For all automotive applications even when the motor is subjected to very strong vibrations, the soldering of the contact pins is sufficient provided the versions with mounting pegs are used. The mounting pegs have been developed to allow screw-free fixing in ALL applications.

#### Examples for Motor Mounting

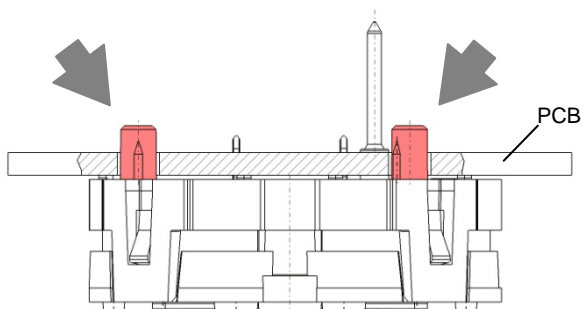
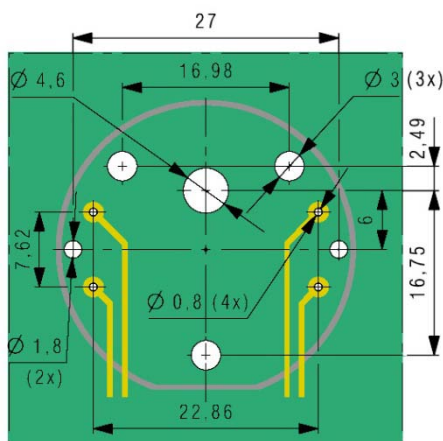

Figure 5: Front contact mount for X27.589

### 3.2 Holes and insertion force

For the recommendations about holes, how to drill support for the stepper motor and the insertion force, refer to the application note AN-JST-001 "Mounting the M-S/ACC Motor".

### 3.3 PCB Layout



This is a suggestion for a Printed Circuit Layout (PCB). Each user can adapt to the needs of the application according to general specification of the product.

Figure 6: PCB Layout

### 3.4 Screwing

As a general rule, screws are unnecessary and should be avoided as much as possible, both for cost and process capability reasons. The motor has a robust design but normal care should be taken that excessive forces do not deform the housing or the shafts.

For further details, refer to the application note AN-JST-001 "Mounting the M-S/ACC Motor".

## 4 Driving the motor

### 4.1 Pin Connection

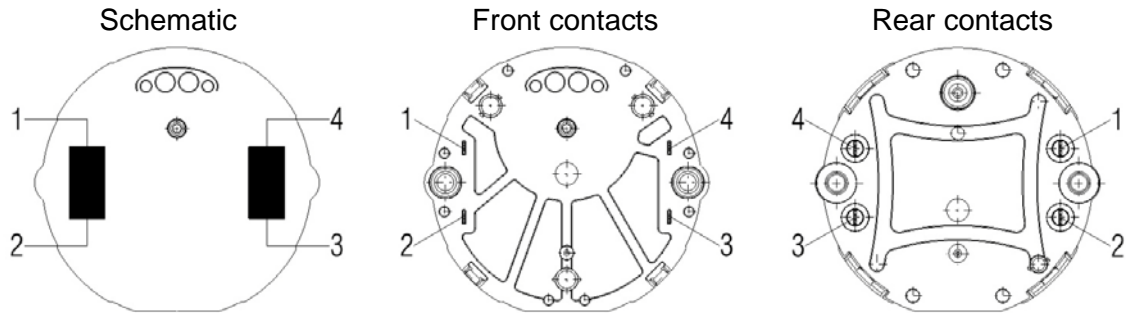

**Figure 7: stepper motor Pinout**

The motor has two coils, called Coil1 and Coil2. The contacts to Coil1 are pin1(+) and pin2(-), the contacts to Coil2 are pin4(+) and pin3(-). The “polarity” on the contacts is indicated to have a reference for the sense of rotation of the motor.

### 4.2 Driving methods

To drive the X27 stepper motor two coils have to be supplied. The typical methods are partial steps or micro-steps. The first has the advantage to require simple output stages with only two levels of voltage, the second has the advantage to create more smooth and precise movement.

**Figure 8: Partial steps mode**

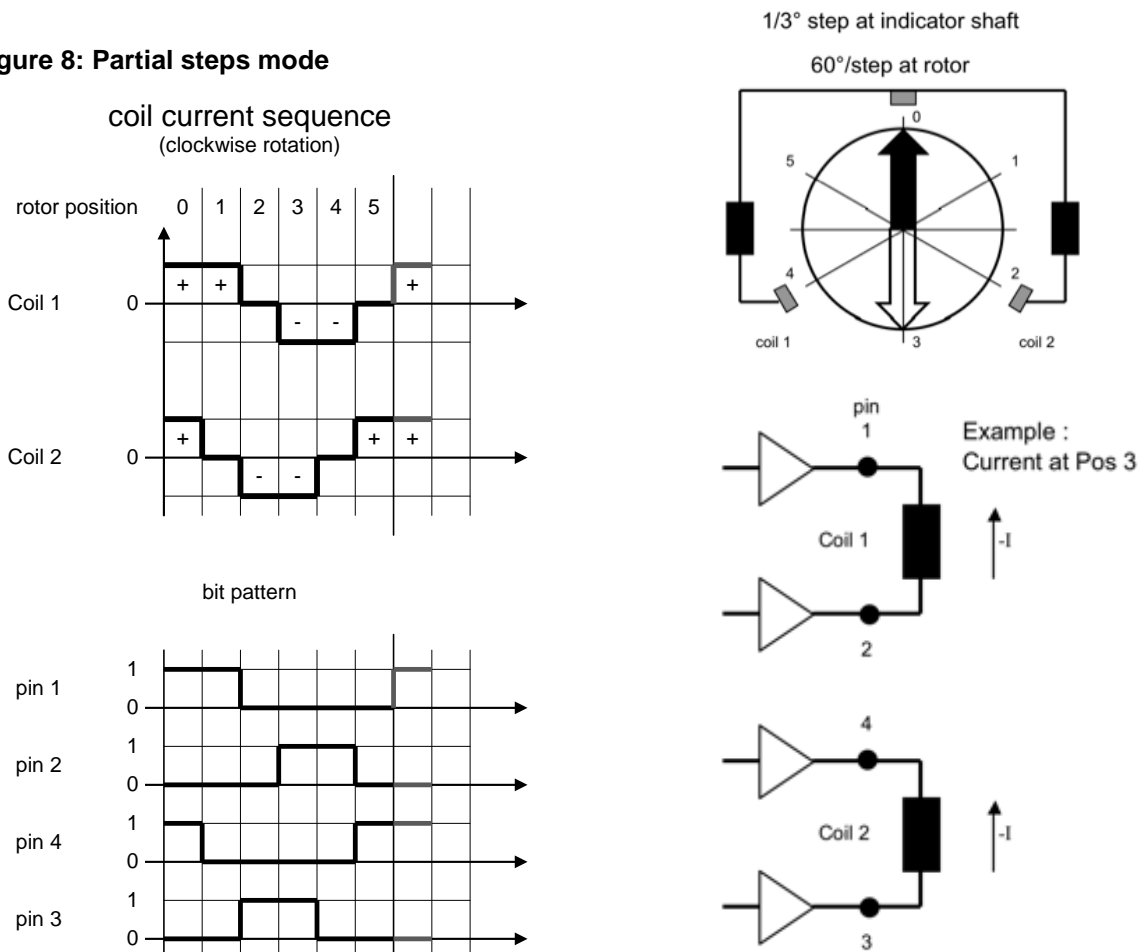

# X27 Stepper Motor Specification

The X27 stepper motor has a gear reduction of 1:180. In other words a full rotation of the rotor makes a rotation of  $2^\circ$  on the indicator shaft.

**Figure 9: Micro steps mode**

**X27 Micro-stepping waveform; 24 steps mode, VDD = 5.0V**

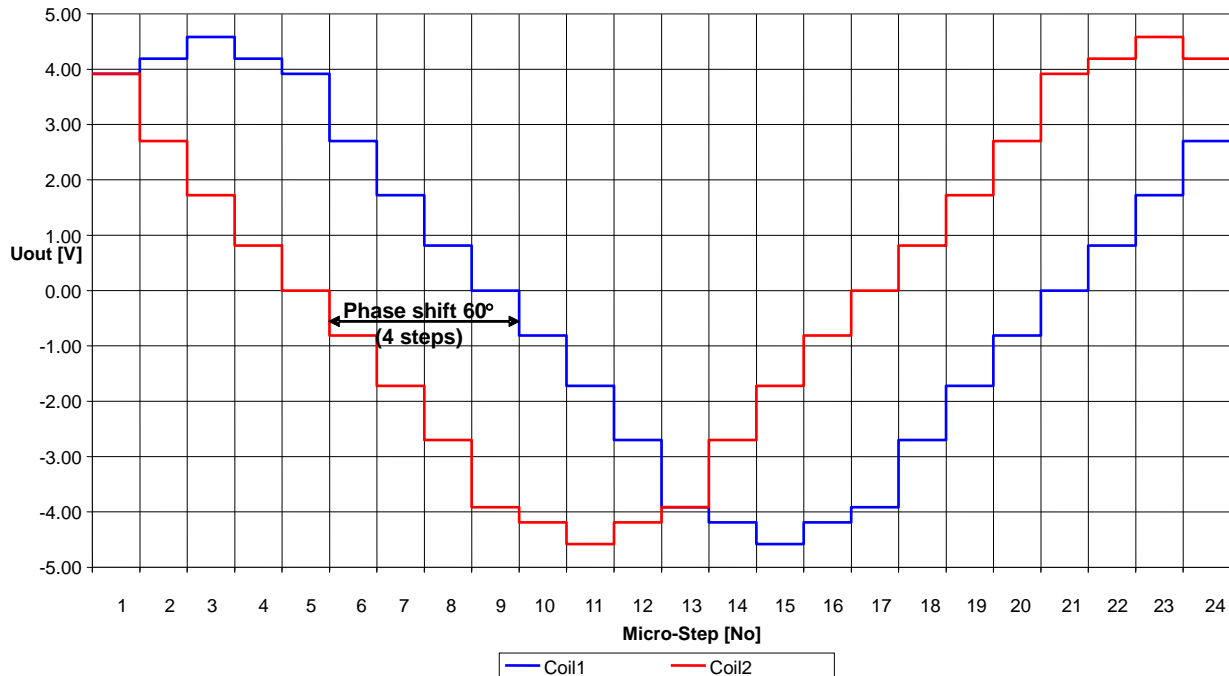

It consists on a subdivision of a full step with different voltage levels. Each revolution of the rotor is parted in several micro-steps. Common values are 24, 48, or 96 micro-steps per full rotor revolution.

For micro-step mode most of the time the inductance characteristic of the coil is exploited. This kind of signals can be generated with a PWM method and relative output circuit.



## 5 Connection with a pointer

The physical link between the pointer and the shafts is a key point. On the X27 we have one metal shaft.

### 5.1 Pointer shape

For the metallic shaft it is suggested a geometry for the hole in the pointer as follow:

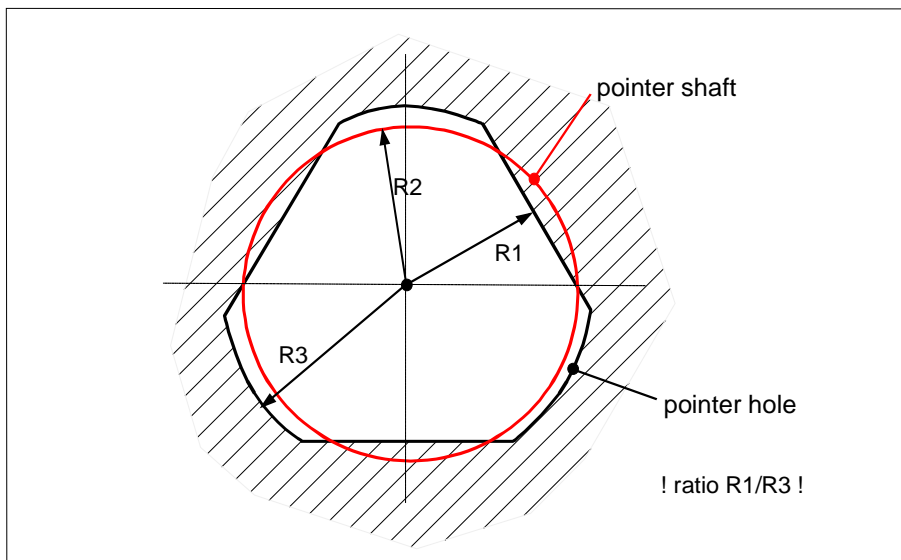

**Figure 10: Pointer hole geometry**

- + High holding torque
- + Low insertion force
- + Larger tolerances of the parts
- + Very high process capability

### 5.2 Pointer stacking

The mounting of the hands on the shafts is usually done in a pressing operation. When using this technique, care should be taken that the forces ( $F_A$  and  $F_Q$ ) do not exceed those given in the specifications.

#### Caution

Care should be taken not to impose excessive acceleration onto the pointer shaft. A kick on the mounted pointer might damage the gear and cause permanent damage to the X27 motor! A typical mistake is to apply compressed air on the motor for cleaning purpose and making the pointer accelerating and damage the internal gear train.

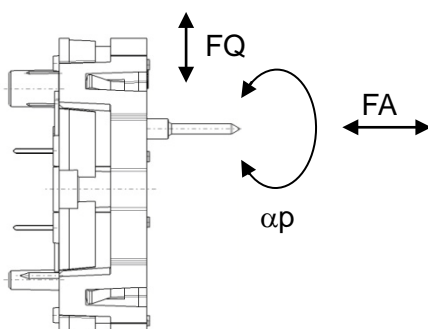

**Figure 11: Forces on the pointer shafts**



# X27 Stepper Motor Specification

Doc. No.: SP-X27-e-C

## 6 Physical dimensions

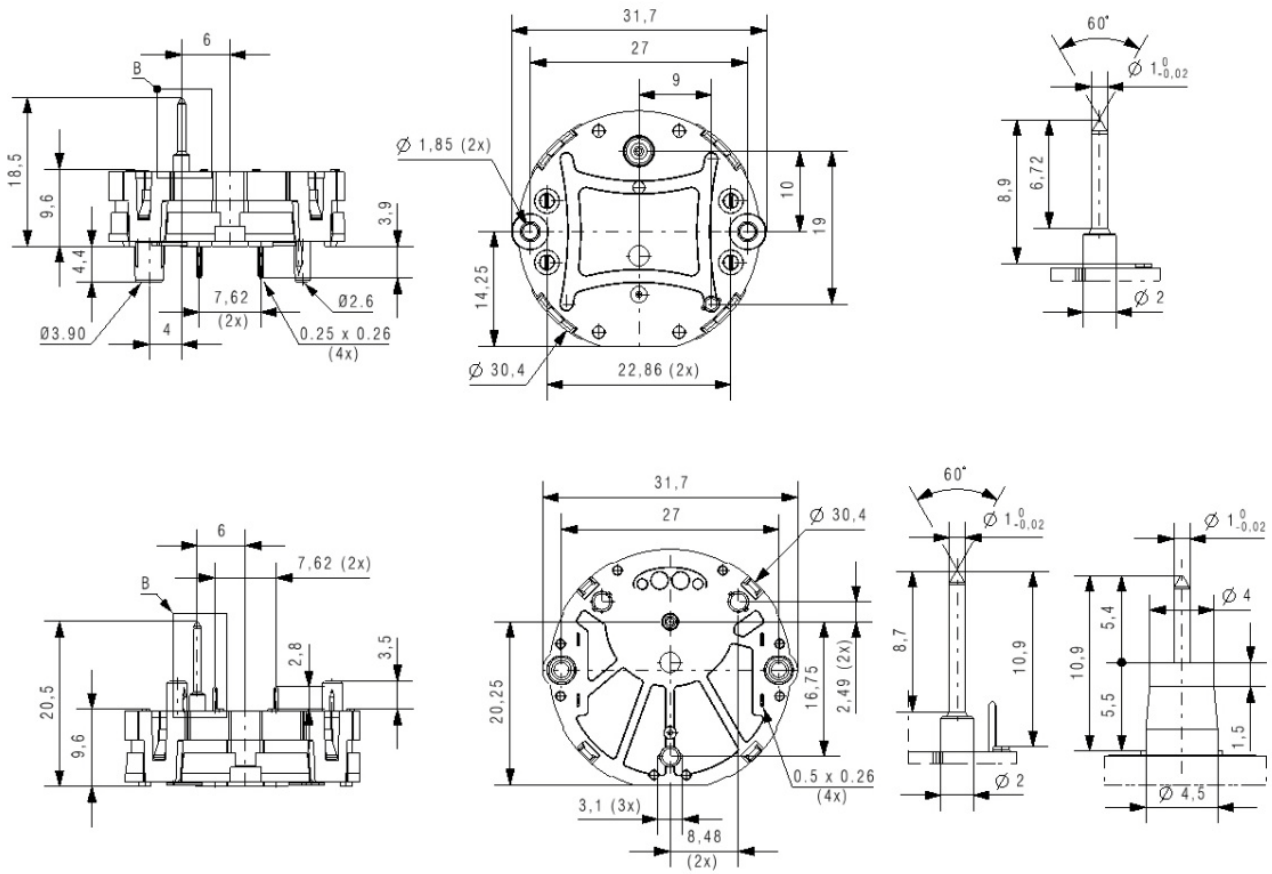

Figure 12: X27 physical dimensions

## 7 Absolute Maximum Ratings

Parameter	Symbol	Conditions
Driving voltage	$U_b$	10 V
ESD tolerance (MIL 883)	$U_{ESD}$	10'000 V
EMI tolerance (1 kHz; AM 80%; 100 kHz - 2 GHz)	E	80 V/m
Storage temperature	$T_{stg}$	105 °C
Solder temperature (10 sec)	$T_s$	260 °C



Stresses beyond these listed maximum ratings may cause permanent damage to the M-S X27. Exposure to conditions beyond specified operating conditions may affect the M-S X27 reliability or cause malfunction.

Stresses beyond these listed maximum ratings may cause permanent damage to the M-S X27. Exposure to conditions beyond specified operating conditions may affect the M-S X27 reliability or cause malfunction.

### 7.1 Electrical and Mechanical Characteristics

$T_{amb} = 25^\circ\text{C}$  and  $U_b = 5\text{ V}$ ; unless otherwise specified.

Parameter	Min.	Type	Max.	Unit
1 Dynamic torque on the pointer shaft at 200°/s and 5.0V <sub>DC</sub> supply	1.0	1.45		mNm
2 Start-Stop speed $\omega_{SS}$ at pointer inertia load $0.2 \times 10^{-6} \text{kgm}^2$			250	°/s
3 Maximum operating speed $\omega_{max}$ with appropriate acceleration			600	°/s
4 Angle of rotation with internal stop			315	Degree
6 Holding torque powered	3.5	4.0		mNm
7 Operating voltage (phase shift 60°)		5	9	V <sub>DC</sub>
8 Coil resistance per coil	230	260	290	$\Omega$
9 Gear play on shaft		0.5	1	Degree
10 Equivalent inertia ( $J_{M-S}$ reported to the indicator shaft)		6.1e-7		Kgm <sup>2</sup>
11 Rotating angle for an electrical period (gear ratio 1:180)		2		Degree
12 Maximum axial force on the pointer shaft (stake-on) Maximum axial force on the pointer shaft (pull-off) Maximum radial force on the pointer shaft			150 100 12	N N N
13 Noise level of the motor, measurement distance 4 cm from top of shaft, not mounted, without load, angular speed 200°/s		40		dB(A)
14 Acceleration of sinus vibration test (5.250 Hz), 8h, each direction, at pointer inertia load $0.2 \times 10^{-6} \text{kgm}^2$		6g		m/s <sup>2</sup>
15 Operating Temperature	-40		105	°C

**Table 1: Electrical and mechanical characteristics**

## 7.2 Typical Performance Characteristics

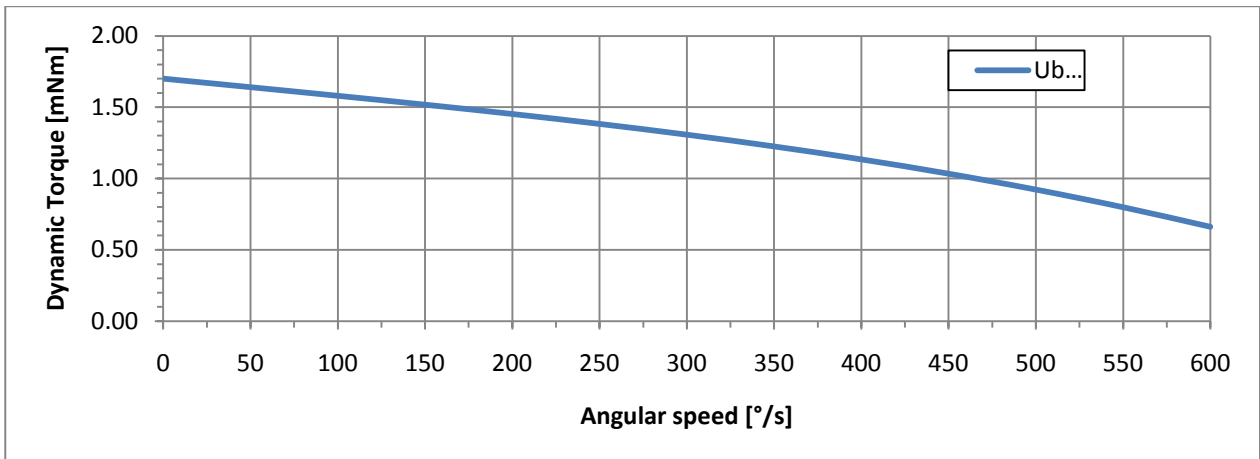
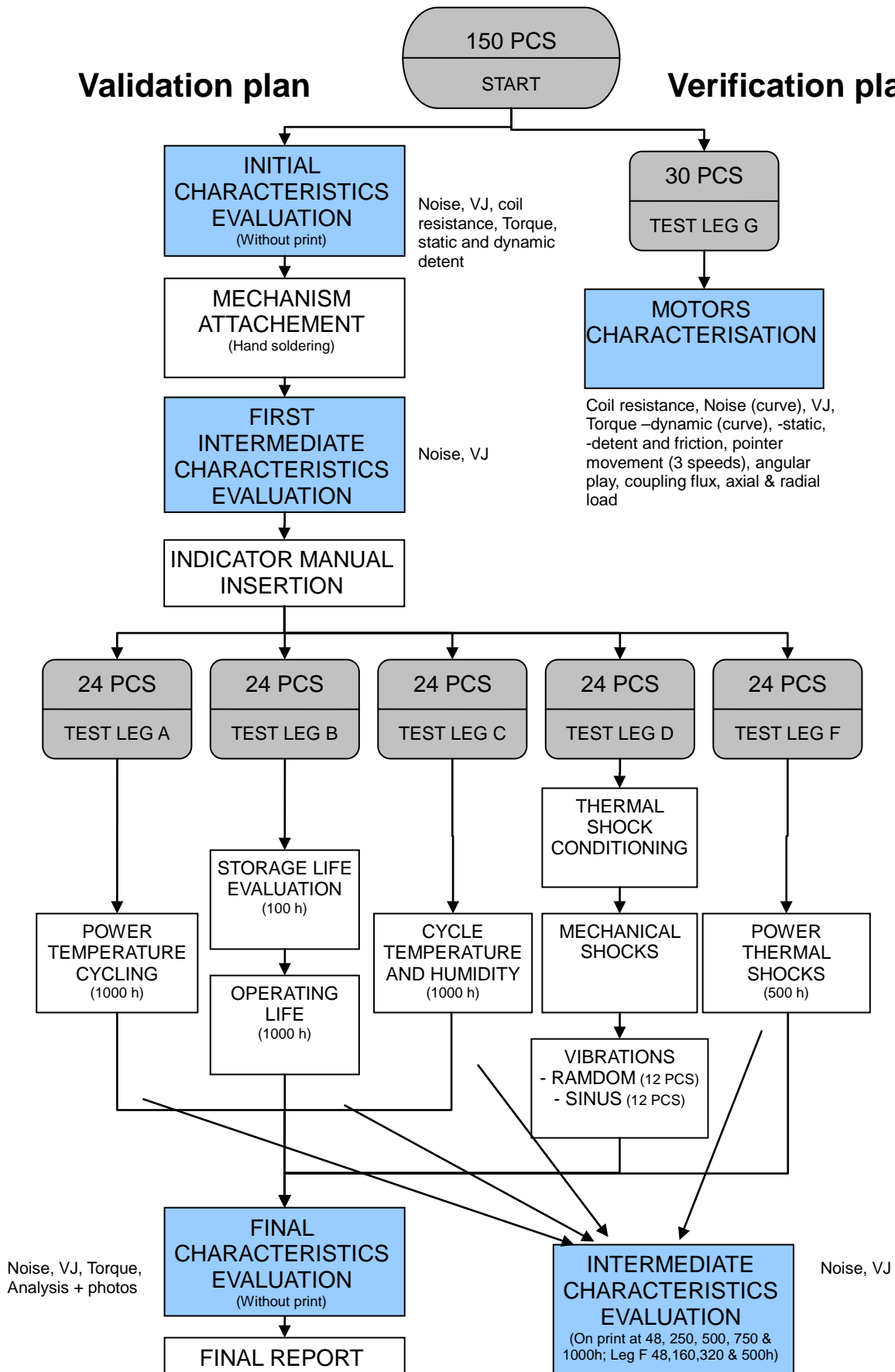

Figure 13: Dynamic Torque  $M_d=f(\omega)$

## 8 Tests description and conditions



## Validation plan

### Initial preconditioning

After the initial characteristics evaluation, the M-S Motors are mounted on a board and soldered with a gap of 0.5 mm.

When soldered, an axial force (FA) of 150 N and a radial force (FQ) of 12 N must be applied on the shaft of all the tested M-S motors. The radial force is applied at 8.5 mm of the top of the cover.

No significant deformation is allowed.

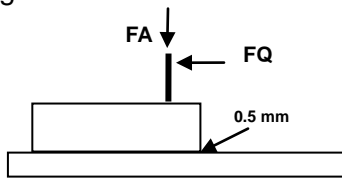

### Standard indicator load

- mass  $m$  : 2.5 g
- inertia  $J_L$  :  $200 \cdot 10^{-9} \text{ kgm}^2$
- unbalance  $M_U$  : 0.01 mNm

### Driving cycles

The driving cycle consists of the following sequential movements in loop.

Before the first cycle, the motors with internal stop are driven continually in the same direction to hit the stop at  $150^\circ/\text{s}$  and then return  $5^\circ$ . The motor is zeroing at this position.

Type of driving speed used according motor type:

	$\omega_1$	$\omega_2$
Driving cycle at high speed:	$200^\circ/\text{s}$	$600^\circ/\text{s}$
Driving cycle at low speed:	$100^\circ/\text{s}$	$300^\circ/\text{s}$

- 1) Driving from  $0^\circ$  to  $60^\circ$  at  $\omega_1$  and wait 1 s.
- 2) Five cycles consisting each of a driving from  $60^\circ$  to  $120^\circ$  at  $\omega_1$  and back to  $60^\circ$  at  $\omega_2$ , Waiting during 2 s after each cycle.
- 3) Back to  $0^\circ$  at  $\omega_1$ .
- 4) **Variante A:** The motor is driven freely without hitting the stop. Driven at  $\omega_2$  to reach  $300^\circ$  ( $360^\circ$  for motors w/o stop) and back again to  $0^\circ$  at  $\omega_2$ .  
**Variante B:** The motor is driven against the stop on versions so fitted in order to increase the shocks and stresses. They drive at  $\omega_2$  to reach  $360^\circ$  and back again of  $360^\circ$  at  $\omega_2$ .

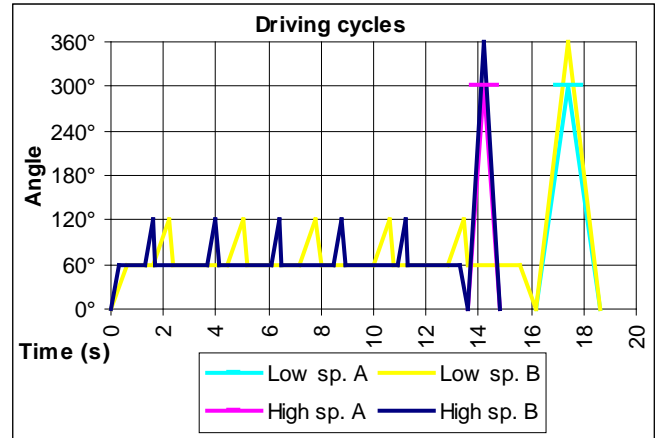

At high speed, the motor is turning about 25% of the time and 75% of the time held on position with appropriate voltage on coils. At low speed, 40% of the time is turning and 60% held on .

## Specific test conditions

### Test Leg A: Power Temperature Cycling

Defect free functioning after passing 1000 h in Temperature Cycling Test during which the clocks are driven.

The temperature cycle consists of  $\frac{1}{2}$  h at  $105^\circ\text{C}$ ,  $\frac{1}{2}$  h to cool down to  $-40^\circ\text{C}$ ,  $\frac{1}{2}$  h at  $-40^\circ\text{C}$  and  $\frac{1}{2}$  h to return to  $105^\circ\text{C}$ . The time of each cycle is 2 h.

The motors are driving during the first 500 h in variante A and during the last 500 h in variante B.

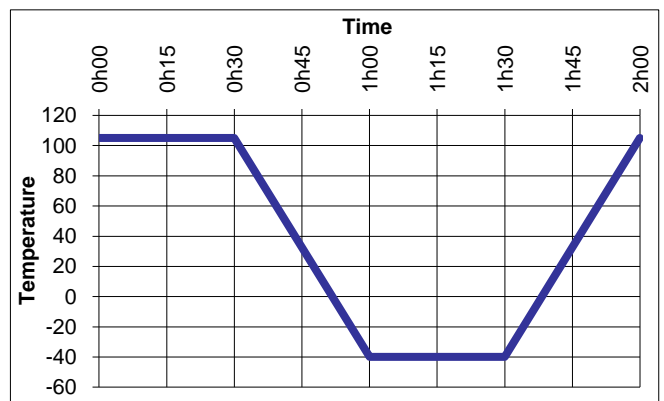

### Test Leg B: Storage and operating life evaluation

Defect free functioning after passing 100 h in Storage Life Evaluation and after 1000 h in Operating Life.

The storage life evaluation consists to place the clocks without rotation at  $-40^\circ\text{C}$  during 100 h. After this time all the clocks must start correctly without step loss.

# X27 Stepper Motor Specification

The operating life consists of a permanent temperature at 105°C during which the motors are driving. The motors are driving during the first 500 h in variant A and during the last 500 h in variant B.

## Test Leg C: Cycle Temperature and Humidity

Defect free functioning after passing 1000 h in Cycle Temperature and Humidity Test during which the clocks are driving.

The cycle temperature and humidity test consists of 8 h cycle as shown on the graph below.

The motors are driving during the first 500 h in variant A and during the last 500 h in variant B.

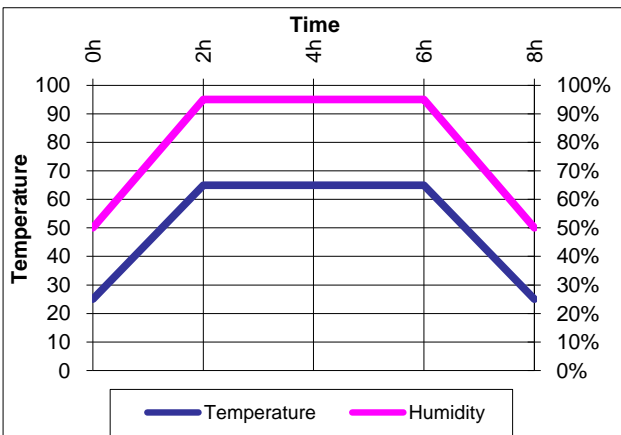

## Test Leg D: Shocks and Vibrations Test

Defect free functioning after being subjected Shocks and Vibrations Tests.

### Thermal shock conditioning

First, the motors are placed without rotation to be conditioned in a thermal shock test which consists of 16 thermal shocks between 85°C and -40°C in < 30 s. The extreme temperatures are maintained ½ h. The time of each cycle is 1 h.

### Mechanical shocks

The motors are subjected to shocks 5 times in 3 axes on the vibration machine. Each shock consists of a half-sine waveform pulse with an acceleration peak of 20 g during 11 ms. The motors are driving in variant A during this test.

### Random vibrations

Previously subjected to thermal/mechanical shocks, one half of the motors are subjected to the random vibrations test in each 3 axes.

Vibrations are applied for 10 minutes at a level of 1.8 grms between 10 and 1000 Hz during which no step loss shall be evident. Then the

clocks are vibrated 20 h at a level of 4.5 grms without mechanical damage and then, they are again vibrated 10 minutes at the level of 1.8 grms. During this last step, no step loss shall be evident. The motors are driving in Variant A during this test.

## Sinus vibrations

Previously subjected to thermal/mechanical shocks, the second half of the motors are subjected to the sinus vibrations test in each 3 axes.

Vibrations are applied for 8 h with an acceleration of 6 gp-p, but maximum 10 mm of amplitude in the frequency range of 5 to 250 Hz with a sweep of 1 octave / minute. The motors are driving in variant A during this test.

## Test Leg F: Power Thermal Shocks

Defect free functioning after passing the test 500 h in Power Thermal Shocks test.

The Power Thermal Shocks test consists of continuous sequential thermal shocks between 105°C and -40°C every 30 minutes during 500 h. The time between both extreme temperatures is < 30sec.

## Driving cycles special for Leg F

The driving cycle consists of a continuous sequential movement in loop. It is only a forth and back at the maximum possible speed terminated with a speed below the start-stop speed to be sure that the rotor makes the kick back.

	$\omega_1$	$\omega_2$
Driving cycle speeds:	600°/s	150°/s

- 1) Driving from 0° to 300° at  $\omega_1$ .
- 2) Driving from 300° to 360° at  $\omega_2$ . The motor is touching the internal stop.
- 3) Driving back to 60° at  $\omega_1$ .
- 4) Driving back from 60° to 0° at  $\omega_2$ .

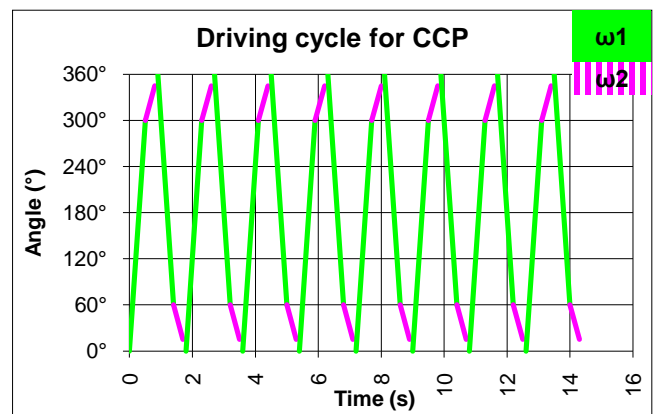

## Verification plan

### Test Leg G: Motor characterisation

For the motor characterisation, 30 motors are measured to verify if each characteristic is in the specified tolerances.

## Measurement methods

### Coil resistance

The coil resistance measurement is mainly to check if the coil is open or not. The tolerances have to be kept and reported at 20°C. (AA-370-21)

### Noise

The noise is measured in a quiet chamber (max 20 dBA) when the motor is turning inside at several rotation speeds. The microphone is placed at a distance of 4 cm from the top of the shaft.

For the characteristics evaluation during the validation phase, the noise is measured when the motor is turning at 50, 100, 200, 400 and 600 degrees/s.

For the verification phase, the noise is measured when the motor is turning at 16 different rotating speeds between 5 and 600 degrees/s. The measured points define a curve which represent the basic noise level for each motor type. (AA-370-22)

### VJ test

The VJ test allows to measure the functioning of an M-S motor and to detect any possible defaults. All new motors pass through this test. Motors which undergo validation tests can have different values than which is set for new motors; because the functions change during the validation phase due to the extreme environmental conditions. An evaluation of the functions is made through the measured values. (AA-370-23)

### Detent torque

This measurement gives the detent torque. This is only an indicative value because the detent torque is influenced by the design of the motor type. (AA-370-24)

### Friction torque

This measurement gives the friction torque. This is only an indicative value because the

friction torque is influenced by the design itself. (AA-370-25)

### Pointer movement

The pointer movement is subjective and there are no values to determine a good or a bad movement. The measuring method is an evaluation of the movement by an operator at several rotating speeds. (AA-370-26)

### Angular play

The angular play has to be in accordance to the specs. This is made at a low and a high speed. The measured value is an absolute value between the position of the staying pointer in one direction and its opposite. (AA-370-27)

### Kick back

The kick back measurement gives the position of the magnetic poles when the pointer touches against the internal stop. (Se AA-370-28)

### Coupling flux

This value is given by the power of the magnet and by the magnetic circuit. This value is a check of the power of the magnet in our motors. (AA-370-29)

### Dynamic torque

The dynamic torque is measured at several rotation speed. This measurement gives the true torque on the output shaft at different position during its complete rotation. (AA-370-30)

### Static torque

The static torque is measured when both coils are powered at the same voltage. (AA-370-31)

### Loads

The motors have to be able to sustain the given loads without any deformation in accordance to the specs. The loads can be axial (push or pull force) or radial. (AA-370-32)



# X27 Stepper Motor Specification

## 9 Packaging

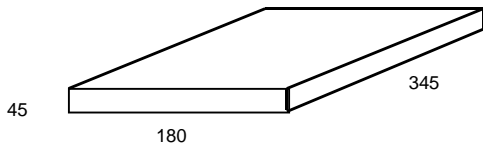

### Tray for 50 Miniature Stepper Motors X27:

Material: Polystyrene – Hardplastic

Weight:	Tray	1 x	210g =	210g
	Motors	50 x	7.5g =	375g
			<b>Total =</b>	<b>585g</b>

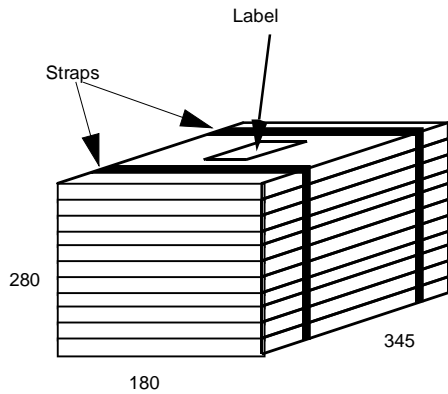

### Stack for 500 Motors:

Material: 11 Trays (including cover) strapped together with plastic band

Weight:	Trays	10 x	585g =	5'850g
	Cover tray	1 x	210g =	210g
	Plastic strap	2 x	15g =	30g
			<b>Total =</b>	<b>6'090g</b>

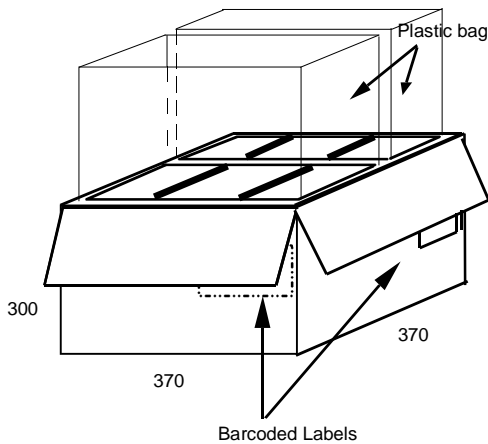

### Cardboard box for 1000 Motors:

Material: Cardboard 740 g/m<sup>2</sup>

Weight:	Cardboard	1 x	900g =	900g
	Plastic bag	2 x	50g =	100g
	Stacks	2 x	6'090g =	12'180g
			<b>Total =</b>	<b>13'180g</b>

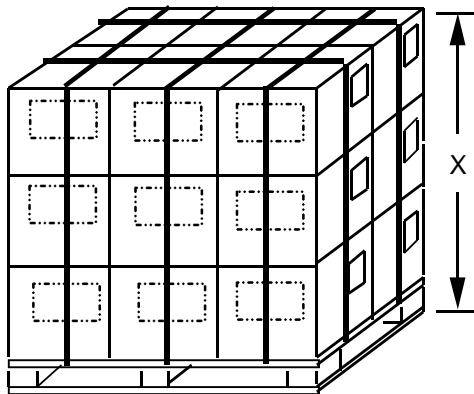

### "Euro-Palette" for 6K/12K/18K/24K Motors:

Material: Euro-Palette (1'200x800x150)

Weight:	Pallet	1 x	20kg =	20kg
---------	--------	-----	--------	------

No. of layers	X	No. of motors	Weight *
1	450mm	6000	100kg
2	750mm	12000	179kg
3	1'050mm	18'000	258kg
4	1'350mm	24'000	336kg

\* Estimated maximum weights

all Dimensions in mm

# X27 Stepper Motor Specification

## 10 Product identification

Each motor is marked with a product number and its manufacturing date:

Hour	Day	Manufacturing place	Week	Year
00   23	1   7	Line 9 - Zhuhai > = Normal prod. \ = Special trace. < = Special trace.	01   52	0   9
		Line 12 - Zhuhai } = Normal prod. # = Special trace. { = Special trace.		

**Table 2: Production code**

Example:

114>32.9      This pieces has been produced during **11<sup>th</sup>** hour (from 11:00 to 11:59), on **4<sup>th</sup>** day (Thursday), > Line 9 in Zhuhai normal production, week **32** of 2009.

### Coding for prototypes

The coding for prototypes and special motor types is printed above or below the production date.

Sample	Variant
A	1
Z	9

Example:

A1      A-sample, variant 1  
114>32.9      This pieces has been produced during **11<sup>th</sup>** hour (from 11:00 to 11:59), on **4<sup>th</sup>** day (Thursday), > Line 9 in Zhuhai normal production, week **32** of 2009.

## 11 Table of Index

<b>1</b>	<b>INTRODUCTION .....</b>	<b>1</b>
1.1	SUMMARY OF FEATURES .....	1
<b>2</b>	<b>FUNCTIONAL DESCRIPTION .....</b>	<b>2</b>
2.1	START-STOP SPEED $\omega_{SS}$ .....	3
2.2	ACCELERATION TO SPEEDS $> \omega_{SS}$ .....	4
<b>3</b>	<b>INSTALLATION AND DIMENSIONS .....</b>	<b>5</b>
3.1	MOTOR MOUNTING .....	5
3.2	HOLES AND INSERTION FORCE .....	5
3.3	PCB LAYOUT .....	5
3.4	SCREWING .....	5
<b>4</b>	<b>DRIVING THE MOTOR .....</b>	<b>6</b>
4.1	PIN CONNECTION .....	6
4.2	DRIVING METHODS .....	6
<b>5</b>	<b>CONNECTION WITH A POINTER .....</b>	<b>8</b>
5.1	POINTER SHAPE.....	8
5.2	POINTER STACKING .....	8
<b>6</b>	<b>PHYSICAL DIMENSIONS .....</b>	<b>9</b>
<b>7</b>	<b>ABSOLUTE MAXIMUM RATINGS .....</b>	<b>10</b>
7.1	ELECTRICAL AND MECHANICAL CHARACTERISTICS .....	10
7.2	TYPICAL PERFORMANCE CHARACTERISTICS .....	11
<b>8</b>	<b>TESTS DESCRIPTION AND CONDITIONS.....</b>	<b>12</b>
<b>9</b>	<b>PACKAGING .....</b>	<b>16</b>
<b>10</b>	<b>PRODUCT IDENTIFICATION .....</b>	<b>17</b>
<b>11</b>	<b>TABLE OF INDEX .....</b>	<b>18</b>
11.1	DOCUMENT HISTORY.....	19
11.2	LEXIC .....	20

# X27 Stepper Motor Specification

FIGURE 1: MAGNETIC CIRCUIT.....	2
FIGURE 2: X27 STEPPER MOTOR CONTACTS.....	2
FIGURE 3: GRAPHIC DETERMINATION OF $\omega_{SS}$ .....	4
FIGURE 4: DETERMINATION OF THE ACCELERATION STEPS.....	4
FIGURE 5: FRONT CONTACT MOUNT FOR X27.589.....	5
FIGURE 6: PCB LAYOUT .....	5
FIGURE 7: STEPPER MOTOR PINOUT .....	6
FIGURE 8: PARTIAL STEPS MODE .....	6
FIGURE 9: MICRO STEPS MODE.....	7
FIGURE 10: POINTER HOLE GEOMETRY.....	8
FIGURE 11: FORCES ON THE POINTER SHAFTS .....	8
FIGURE 12: X27 PHYSICAL DIMENSIONS.....	9
FIGURE 13: DYNAMIC TORQUE $M_D=F(\omega)$ .....	11
TABLE 1: ELECTRICAL AND MECHANICAL CHARACTERISTICS .....	10
TABLE 2: PRODUCTION CODE .....	17

## 11.1 Document history

History of document editions:			
	Creation : Date / Abbreviation	Check : Date / Abbreviation	Release : Date / Abbreviation
1 <sup>st</sup> edition - A	09.07.10 / R. Esposito	02.09.10 / D. Maeder	03.09.10 / G. Nambuseril
Revision - B	19.01.11 / N. Gobeli	01.02.11 / D. Maeder	02.02.11 / R. Esposito
Modifications purpose	Content update and completion		
Revision - C	03.06.11 / R. Esposito	03.06.11 / D. Maeder	03.06.11 / G. Nambuseril
Modifications purpose	Chapter 7.1 and 9 updated		
Revision - D			
Modifications purpose			

# X27 Stepper Motor Specification

## 11.2 Lexic

ASIC	Application Specific Integrated Circuit
CCW	Counter Clock Wise
CW	Clock Wise
PCB	Printed Circuit Board
PWM	Pulse Width Modulated
X27	Product name

Parameter	Description	Unit
E	EMI tolerance	V/m
F <sub>A</sub>	axial force on the pointer shafts	N
F <sub>Q</sub>	radial force on the pointer shafts	N
Gnd	ground	-
I <sub>b</sub>	coil current	A
i <sub>m</sub>	operating current	mA
L <sub>m</sub>	measurement distance	cm
m	mass of the driven load	g
M <sub>d</sub>	dynamic torque	mNm
M <sub>0</sub>	static torque at U <sub>b</sub> = 0 V	mNm
M <sub>s</sub>	static torque at U <sub>b</sub> > 0 V	mNm
R <sub>b</sub>	coil resistance	Ω
SPL	noise level of the motor (sound pressure level)	dB
T <sub>a</sub>	temperature	°C
T <sub>amb</sub>	ambient temperature	°C
T <sub>s</sub>	solder temperature	°C
T <sub>stg</sub>	storage temperature	°C
t <sub>m</sub>	measurement time	s
U <sub>b</sub>	coil voltage	V
U <sub>bs</sub>	magnetic saturation voltage	V
UESD	Electro Static Discharge tolerance	V
V <sub>dd</sub>	operating voltage	V