

NMB PERMANENT MAGNET (PM) STEP MOTORS

Custom Features and Options

Extensive in-house machining and production capabilities enable NMB to manufacture motors with a wide variety of custom features. Listed below are some of the features and options available for NMB Permanent Magnet (PM) motors. Please discuss other options not specifically mentioned here with your NMB sales engineer.

- **PG** motors are PM motors with a plastic planetary gear box.
- **PL** (Lead Screw) motors are PM motors with a non-standard threaded shaft (e.g. molded plastic thread.)
- **PL** (Linear) motors are linear actuators based on PM construction.

1. An encapsulated stator design gives greater dimensional control and improved thermal characteristics.
2. Custom and standard shaped mounting plates are available. Mounting holes can be:
 - Threaded
 - Tapped
 - Slotted
 - Custom
3. Three different types of permanent magnets are available.
 - Ferrite Plastic Magnet
 - Ferrite Sintered Magnet
 - Nd-Fe-B Bonded Magnet
4. Long life oil impregnated bushings are used in PM, PG, and PL (Lead Screw) type motors. NMB ball bearings are used in PL (Linear) type motors.

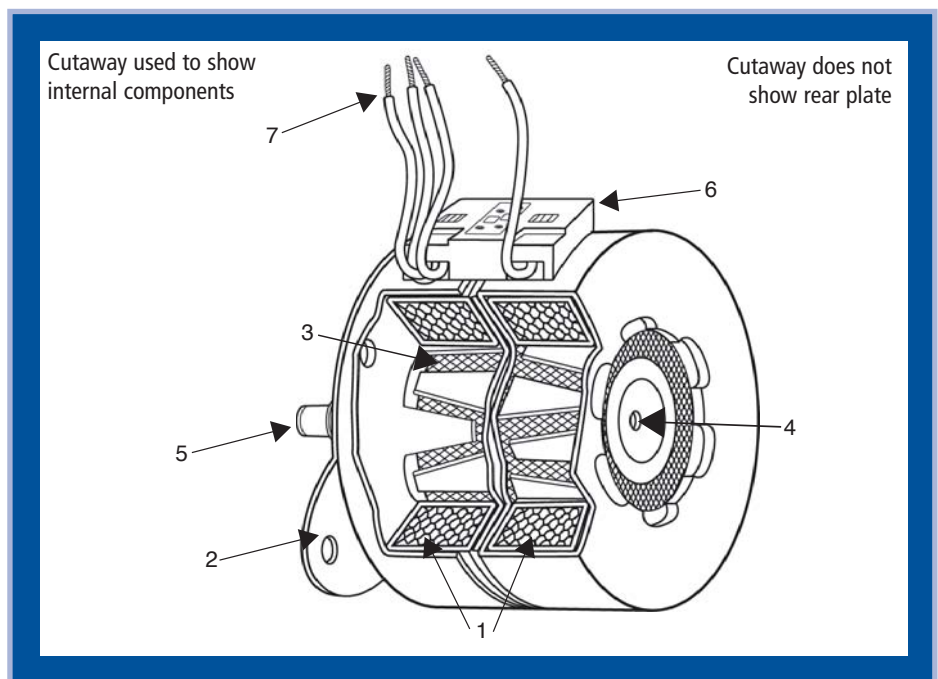

5. A variety of shaft, gear & pulley options are available.

Shafts:

- Custom Lengths
- Single & Double Shafts
- D-cut/s
- Turn Downs
- Thru-Holes
- Threaded
- Knurled
- Grooved

Gears & Pulleys:

- Machined
- Plastic Molded
- Powdered Metal (Sintered)

6. Motor side connection method & lead wire options.

Lead Wire:

- Lead Wire Exit Direction / Exit Angles

Motor Side Connection Method:

- Wire Holder Type Connector (4 or 5 leads)
- Printed Circuit Board (PCB) With Connector
- Pin Terminal
- Flexible Printed Circuit (FPC)

7. Driver side connector options:

- Standard
- Special Order (Non-NMB standard)
- None (Flying leads)

Note: The availability of some features and options may vary depending on the motor type and frame size.

PM SERIES STEP MOTORS

Model Numbering System

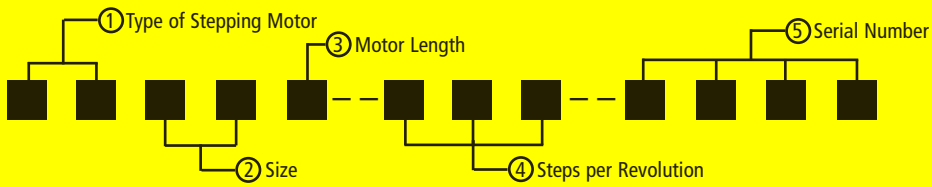

- ① Type of Stepping Motor
PM....Permanent Magnet
PLLead Screw/Linear Type
PGGeared Type
- ② Size
Motor O.D. in mm
(Ex: Size 10 = 10mm Dia.)
- ③ Motor Length
SShort
M....Medium
LLong
- ④ Steps per Revolution
Number of Steps per Rotation
(Ex: 020 = 18 Degree Steps)
- ⑤ Serial Number

General Specifications

Insulation Resistance.....	100M Ω MIN
Dielectric Strength.....	500V AC 1 min
Class of Insulation.....	Class E
Ambient Temperature Range.....	-10°C ~ +50°C
Storage Temperature.....	-30°C ~ +80°C
Ambient Humidity.....	20% RH ~ 90% RH

Motor Unit Wiring Diagram

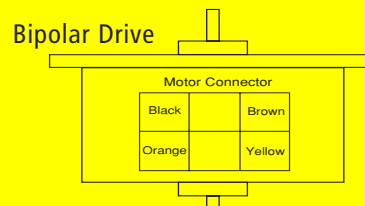
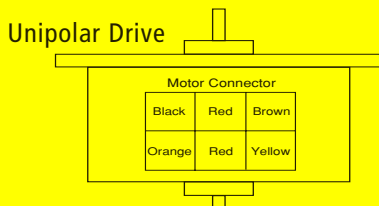

Winding Diagram and Switching Sequence

Unipolar Drive

	Black	Brown	Orange	Yellow	Red/Red
1	-			-	+
2	-		-		+
3		-	-		+
4		-		-	+

CW Rotation Facing Mounting End

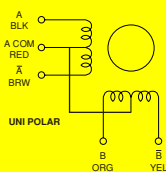

Bipolar Drive

	Black	Brown	Orange	Yellow
1	-	+	+	-
2	-	+	-	+
3	+	-	-	+
4	+	-	+	-

CW Rotation Facing Mounting End

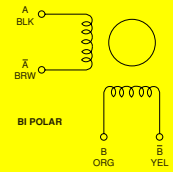

Coil Connectors attached to the motor are force inserted and cannot be removed.

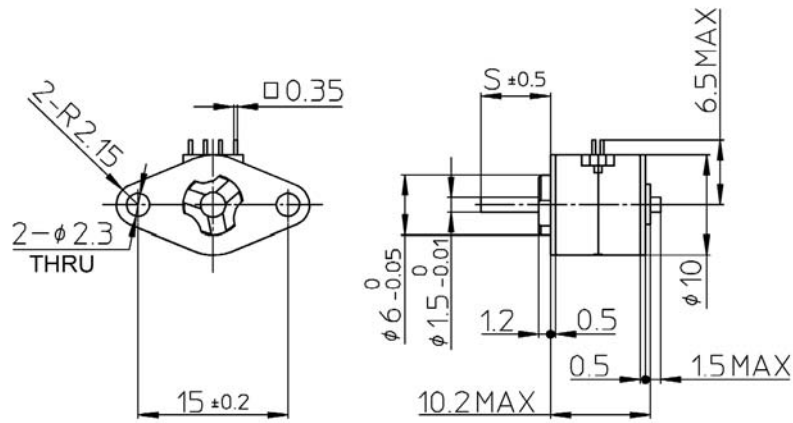

UNIT: mm

Model Specifications

Reference Characteristics	
Motor Size	PM10S-020
No. of Steps per Rotation	20 (18° / Step)
Drive Method	2-2 PHASE
Drive Circuit	BIPOLAR CONST. VOLT.
Drive Voltage	5 [V]
Current / PHASE	
Coil Resistance / PHASE	20 [Ω]
Drive IC	L293D
Magnet Material	Nd-Fe-B bonded magnet

Torque/Speed Characteristics

PM10S-020 BI-CONST. V (at 5 [V], 20 [Ω])

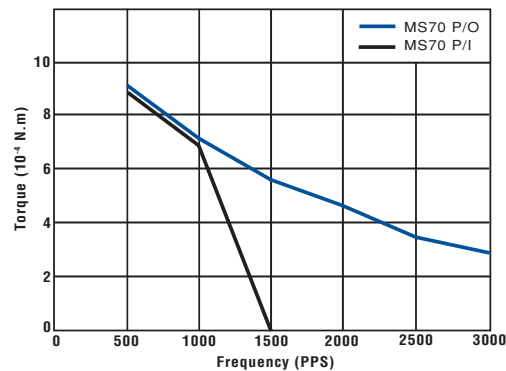

PM15S-020

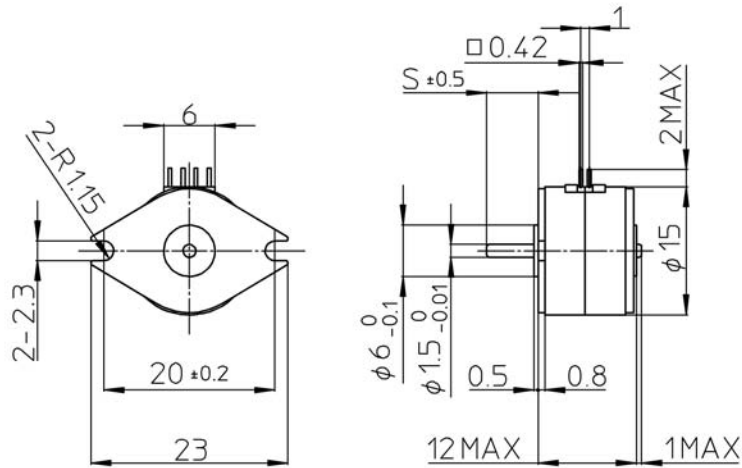

UNIT: mm

Note: See page 38 for options on pin exit angle (θ).

Model Specifications

Reference Characteristics

Motor Size	PM15S-020
No. of Steps per Rotation	20 (18° / Step)
Drive Method	2-2 PHASE
Drive Circuit	BIPOLAR CONST. VOLT.
Drive Voltage	12 [V]
Current / PHASE	
Coil Resistance / PHASE	100 [Ω]
Drive IC	L293D
Magnet Material	Nd-Fe-B bonded magnet

Torque/Speed Characteristics

PM15S-020 BI-CONST. V (at 12 [V], 100 [Ω])

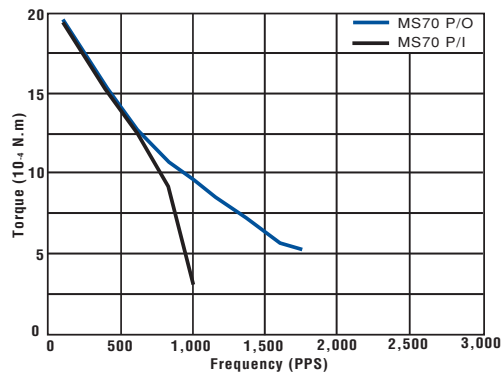

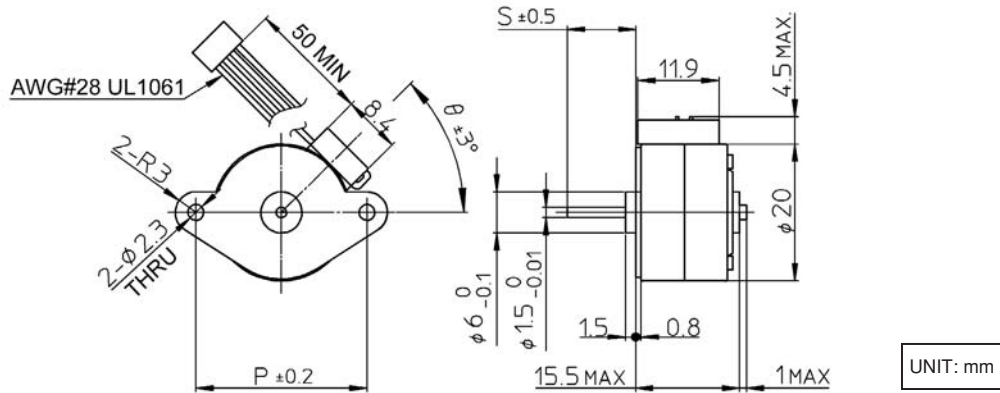

Note: See page 38 for options on pitch (P), mounting holes (H) and lead wire exit angle (θ).

Model Specifications

Reference Characteristics

Motor Size	PM20S-020
No. of Steps per Rotation	20 (18° / Step)
Drive Method	2-2 PHASE
Drive Circuit	UNIPOLAR CONST. VOLT.
Drive Voltage	12 [V]
Current / PHASE	
Coil Resistance / PHASE	50 [Ω]
Drive IC	SMDT - 002
Magnet Material	Nd-Fe-B bonded magnet

Torque/Speed Characteristics

PM20S-020 UNI-CONST. V (at 12 [V], 50 [Ω])

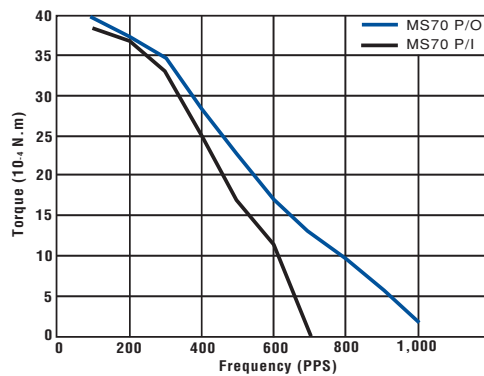

PM20L-020

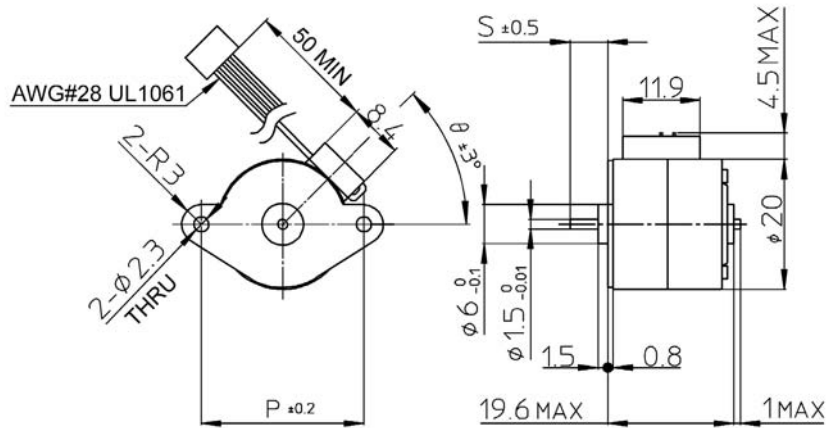

UNIT: mm

Note: See page 38 for options on pitch (P), mounting holes (H) and lead wire exit angle (θ).

Model Specifications

Reference Characteristics	
Motor Size	PM20L-020
No. of Steps per Rotation	20 (18° / Step)
Drive Method	2-2 PHASE
Drive Circuit	UNIPOLAR CONST. VOLT.
Drive Voltage	12 [V]
Current / PHASE	
Coil Resistance / PHASE	100 [Ω]
Drive IC	SMDT - 002
Magnet Material	Nd-Fe-B bonded magnet

Torque/Speed Characteristics

PM20L-020 UNI-CONST. V (at 12 [V], 100 [Ω])

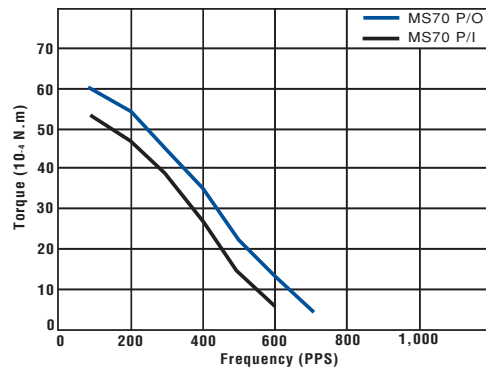

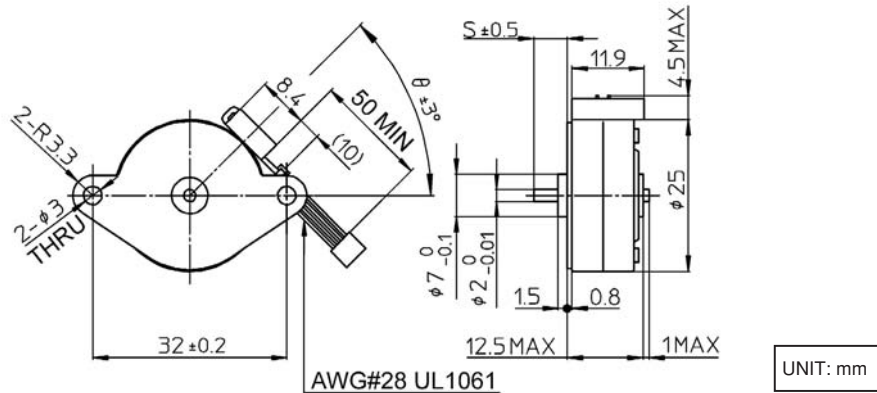

Note: See page 38 for options on mounting holes (H) and lead wire exit angle (θ).

Model Specifications

Reference Characteristics	
Motor Size	PM25S-024
No. of Steps per Rotation	24 (15° / Step)
Drive Method	2-2 PHASE
Drive Circuit	UNIPOLAR CONST. VOLT.
Drive Voltage	24 [V]
Current / PHASE	
Coil Resistance / PHASE	70 [Ω]
Drive IC	SMDT - 002
Magnet Material	Polar anisotropy ferrite sintered magnet, Nd-Fe-B bonded magnet

Torque/Speed Characteristics

PM25S-024 UNI-CONST. V (at 24 [V], 70 [Ω])

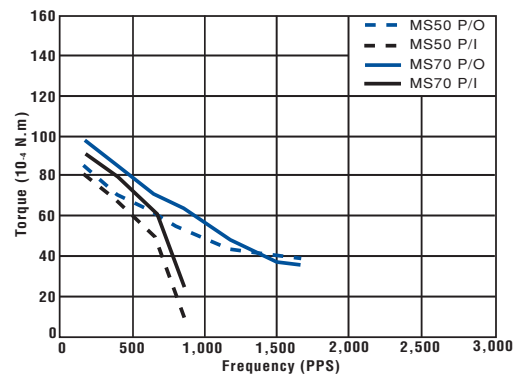

PM25S-048

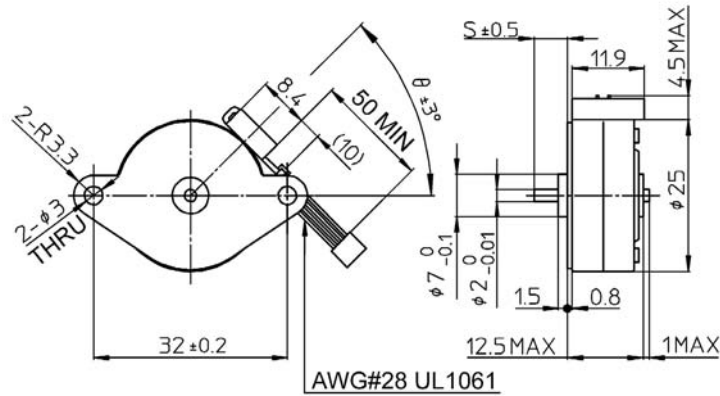

UNIT: mm

Note: See page 38 for options on mounting holes (H) and lead wire exit angle (θ).

Model Specifications

Reference Characteristics

Motor Size	PM25S-048	
No. of Steps per Rotation	48 (7.5° / Step)	
Drive Method	2-2 PHASE	
Drive Circuit	UNIPOLAR CONST. VOLT.	BIPOLAR CHOPPER
Drive Voltage	12 [V]	24 [V]
Current / PHASE	600 [mA]	
Coil Resistance / PHASE	65 [Ω]	14 [Ω]
Drive IC	SMDT - 002	UDN2916B-V
Magnet Material	Nd-Fe-B bonded magnet	

Torque/Speed Characteristics

PM25S-048 UNI-CONST. V (at 12 [V], 65 [Ω])

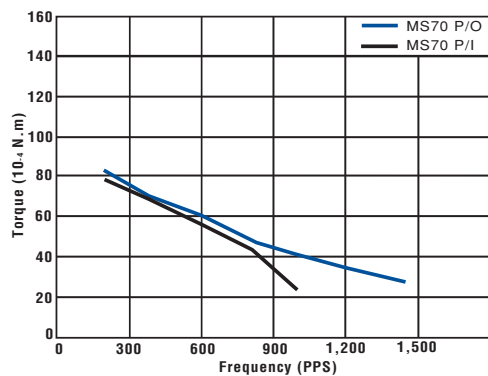

PM25S-048 BI-CHOPPER (at 24 [V], 14 [Ω], 600 [mA])

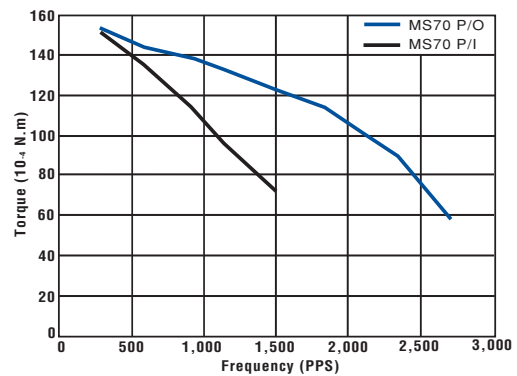

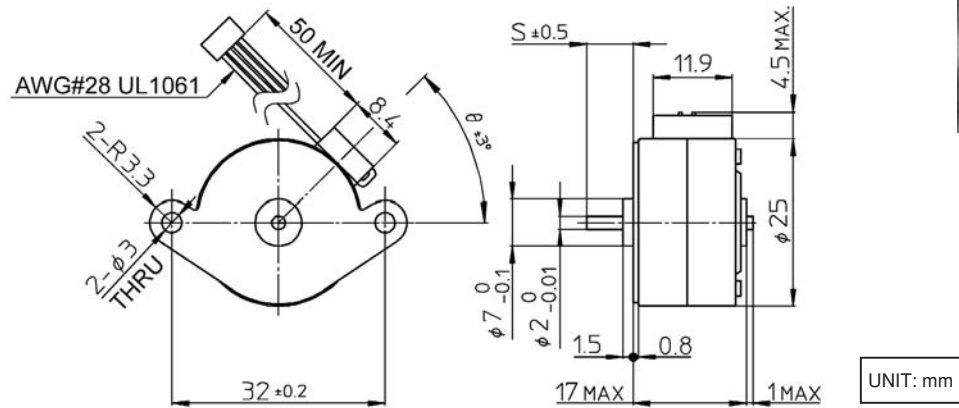

Note: See page 38 for options on mounting holes (H) and lead wire exit angle (θ).

Model Specifications

Reference Characteristics		
Motor Size	PM25L-024	
No. of Steps per Rotation	24 (15° / Step)	
Drive Method	2-2 PHASE	
Drive Circuit	UNIPOLAR CONST. VOLT.	BIPOLAR CHOPPER
Drive Voltage	12 [V]	24 [V]
Current / PHASE	600 [mA]	
Coil Resistance / PHASE	50 [Ω]	8 [Ω]
Drive IC	SMDT - 002	UDN2916B-V
Magnet Material	Polar anisotropy ferrite sintered magnet, Nd-Fe-B bonded magnet	

Torque/Speed Characteristics

PM25L-024 UNI-CONST. V (at 12 [V], 50 [Ω])

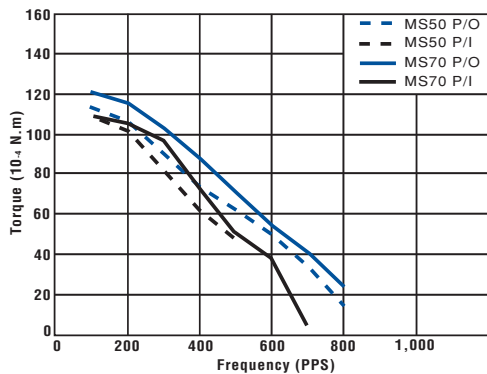

PM25L-024 BI-CHOPPER (at 24 [V], 8 [Ω], 600 [mA])

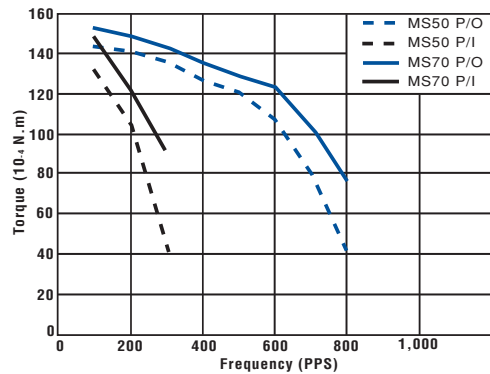

PM35S-024

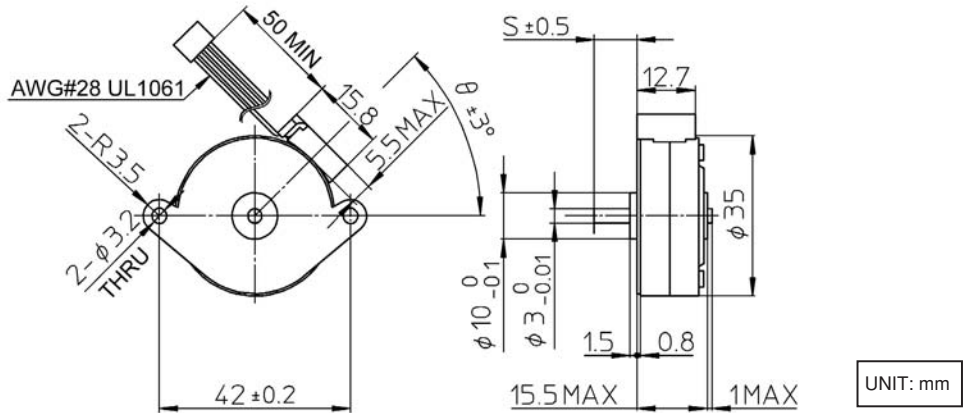

UNIT: mm

Note: See page 38 for options on mounting holes (H) and lead wire exit angle (θ).

Model Specifications

Reference Characteristics		
Motor Size	PM35S-024	
No. of Steps per Rotation	24 (15° / Step)	
Drive Method	2-2 PHASE	
Drive Circuit	UNIPOLAR CONST. VOLT.	BIPOLAR CHOPPER
Drive Voltage	12 [V]	24 [V]
Current / PHASE	500 [mA]	
Coil Resistance / PHASE	28 [Ω]	4.7 [Ω]
Drive IC	SMDT - 002	UDN2916B-V
Magnet Material	Polar anisotropy ferrite sintered magnet	

Torque/Speed Characteristics

PM35S-024 UNI-CONST. V (at 12 [V], 28 [Ω])

PM35S-024 BI-CHOPPER (at 24 [V], 4.7 [Ω], 500 [mA])

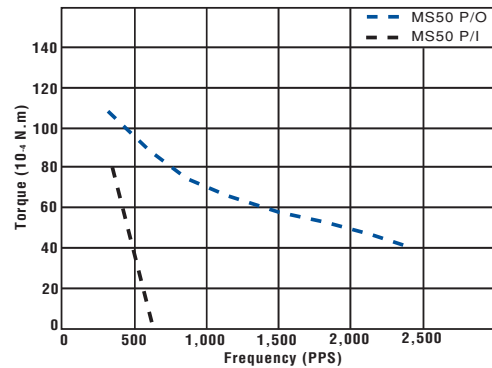
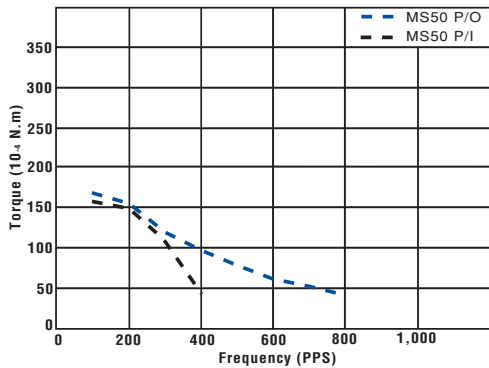

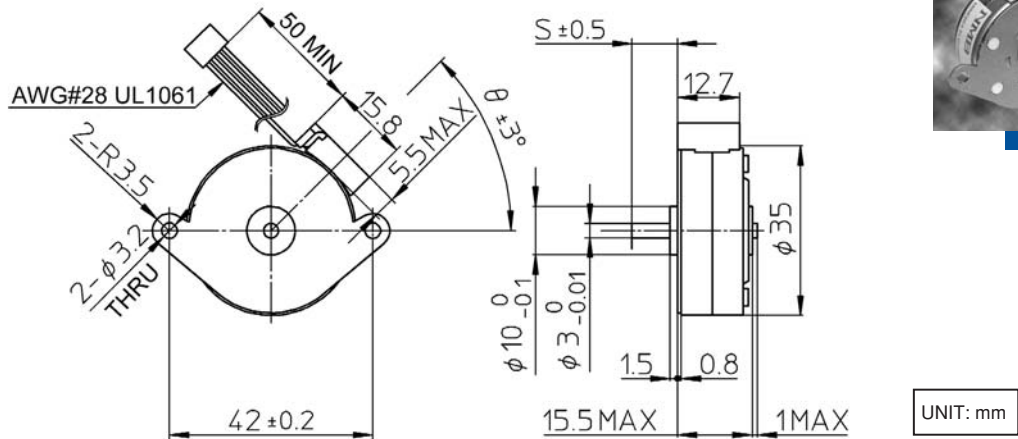

Note: See page 38 for options on mounting holes (H) and lead wire exit angle (θ).

Model Specifications

Reference Characteristics

Motor Size	PM35S-048	
No. of Steps per Rotation	48 (7.5° / Step)	
Drive Method	2-2 PHASE	
Drive Circuit	UNIPOLAR CONST. VOLT.	BIPOLAR CHOPPER
Drive Voltage	24 [V]	24 [V]
Current / PHASE	500 [mA]	
Coil Resistance / PHASE	50 [Ω]	15 [Ω]
Drive IC	SMDT - 002	UDN2916B-V
Magnet Material	Ferrite plastic magnet, Polar anisotropy ferrite sintered magnet, Nd-Fe-B bonded magnet	

Torque/Speed Characteristics

PM35S-048 UNI-CONST. V (at 24 [V], 50 [Ω])

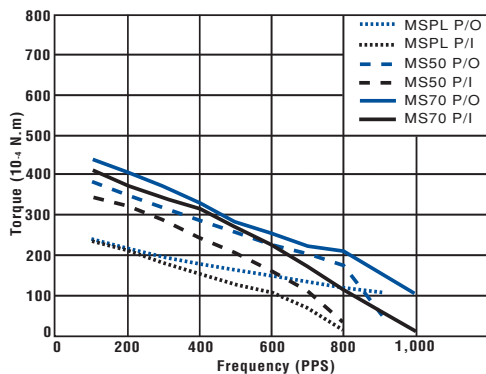

PM35S-048 BI-CHOPPER (at 24 [V], 15 [Ω], 500 [mA])

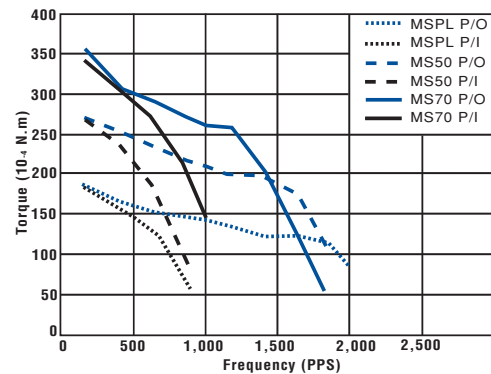

PM35L-024

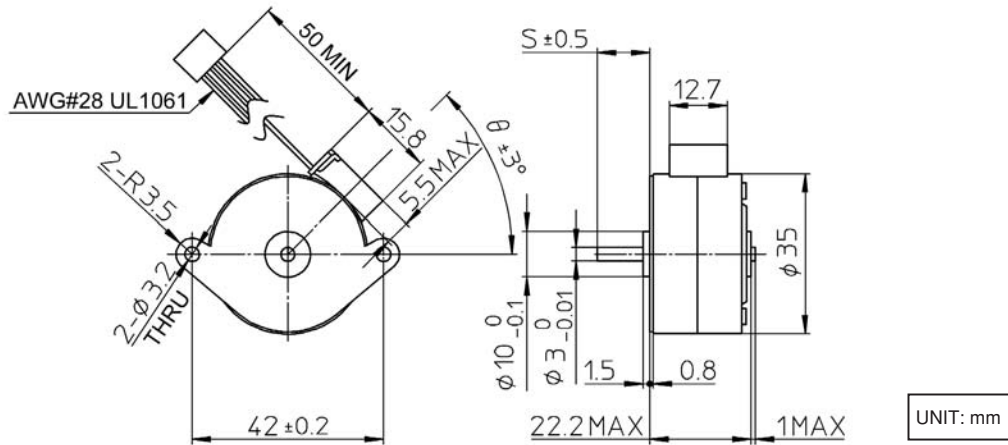

Note: See page 38 for options on mounting holes (H) and lead wire exit angles (θ).

Model Specifications

Reference Characteristics

Motor Size	PM35L-024	
No. of Steps per Rotation	24 (15° / Step)	
Drive Method	2-2 PHASE	
Drive Circuit	UNIPOLAR CONST. VOLT.	BIPOLAR CHOPPER
Drive Voltage	24 [V]	24 [V]
Current / PHASE	500 [mA]	
Coil Resistance / PHASE	100 [Ω]	15 [Ω]
Drive IC	SMDT - 002	UDN2916B-V
Magnet Material	Ferrite plastic magnet, Polar anisotropy ferrite sintered magnet	

Torque/Speed Characteristics

PM35L-024 UNI-CONST. V (at 24 [V], 100 [Ω])

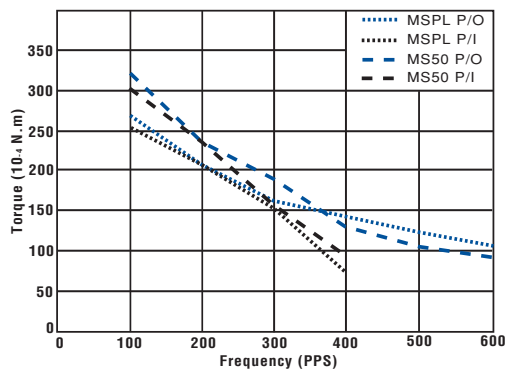

PM35L-024 BI-CHOPPER (at 24 [V], 15 [Ω], 500 [mA])

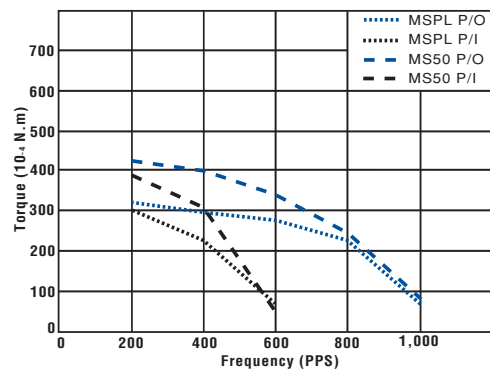

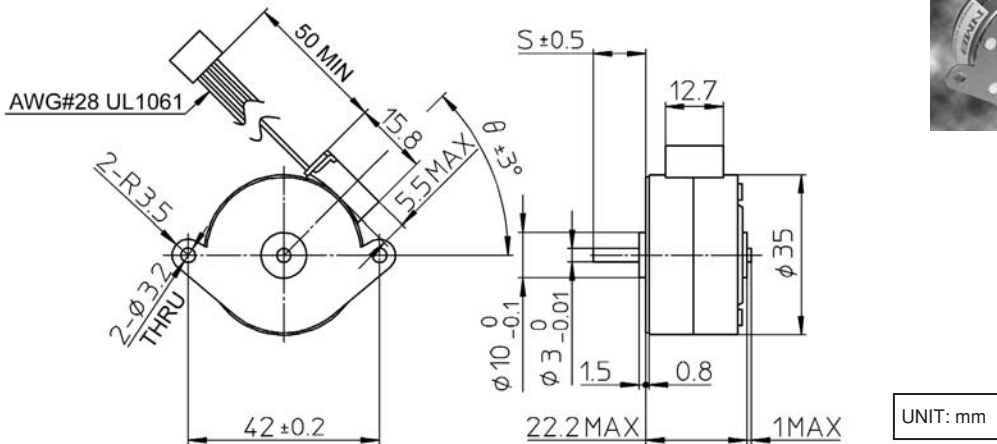

Note: See page 38 for options on mounting holes (H) and lead wire exit angle (θ).

Model Specifications

Reference Characteristics		
Motor Size	PM35L-048	
No. of Steps per Rotation	48 (7.5° / Step)	
Drive Method	2-2 PHASE	
Drive Circuit	UNIPOLAR CONST. VOLT.	BIPOLAR CHOPPER
Drive Voltage	24 [V]	24 [V]
Current / PHASE	600 [mA]	
Coil Resistance / PHASE	30 [Ω]	5.5 [Ω]
Drive IC	SMDT - 002	UDN2916B-V
Magnet Material	Ferrite plastic magnet, Polar anisotropy ferrite sintered magnet, Nd-Fe-B bonded magnet	

Torque/Speed Characteristics

PM35L-048 UNI-CONST. V (at 24 [V], 30 [Ω])

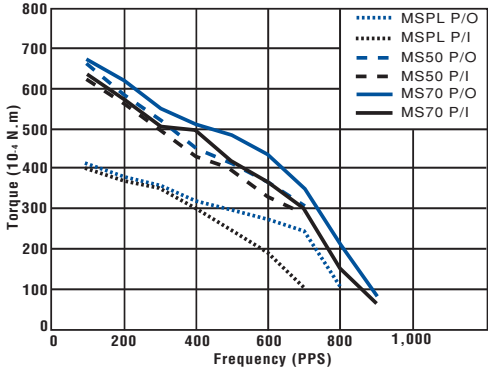

PM35L-048 BI-CHOPPER (at 24 [V], 5.5 [Ω], 600 [mA])

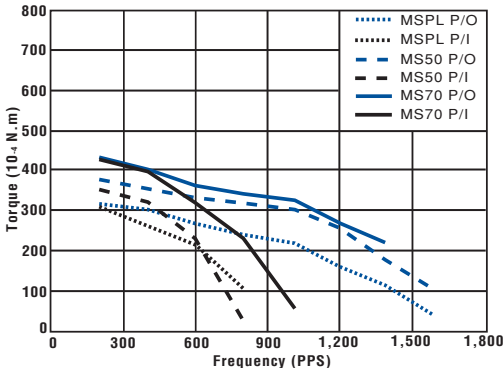

PM42S-048

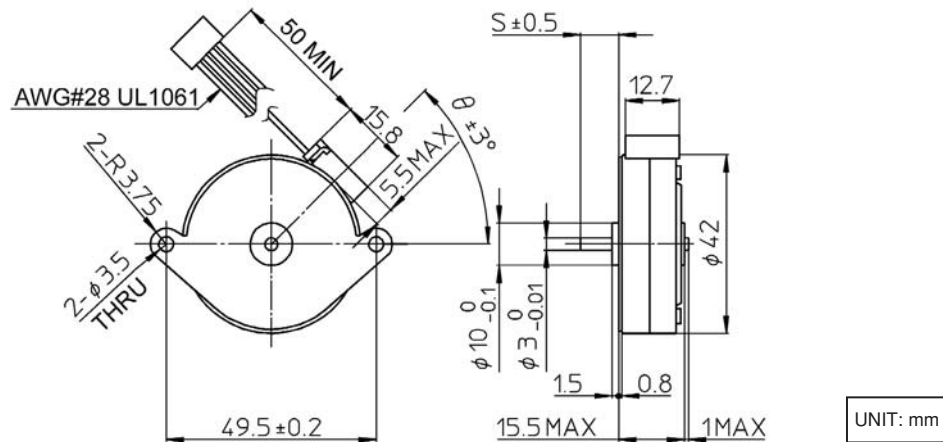

Note: See page 38 for options on mounting holes (H) and lead wire exit angle (θ).

Model Specifications

Reference Characteristics

Motor Size	PM42S-048	
No. of Steps per Rotation	48 (7.5° / Step)	
Drive Method	2-2 PHASE	
Drive Circuit	UNIPOLAR CONST. VOLT.	BIPOLAR CHOPPER
Drive Voltage	24 [V]	24 [V]
Current / PHASE	500 [mA]	
Coil Resistance / PHASE	45 [Ω]	7 [Ω]
Drive IC	SMDT - 002	UDN2916B-V
Magnet Material	Ferrite plastic magnet, Polar anisotropy ferrite sintered magnet, Nd-Fe-B bonded magnet	

Torque/Speed Characteristics

PM42S-048 UNI-CONST. V (at 24 [V], 45 [Ω])

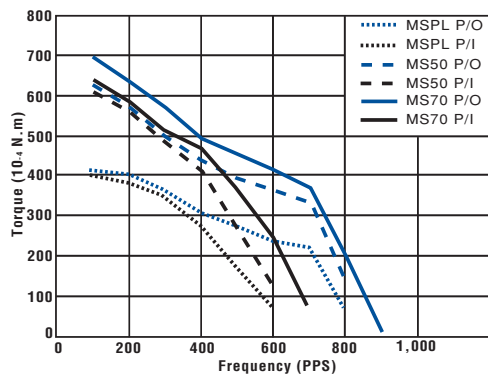

PM42S-048 BI-CHOPPER (at 24 [V], 7 [Ω], 500 [mA])

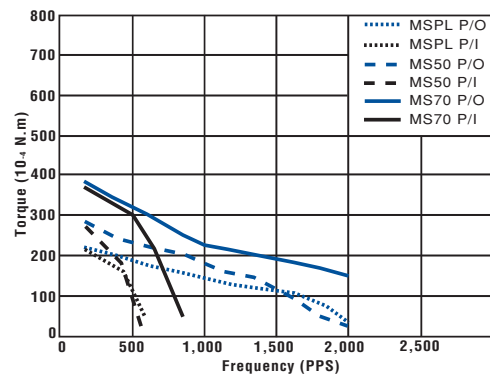

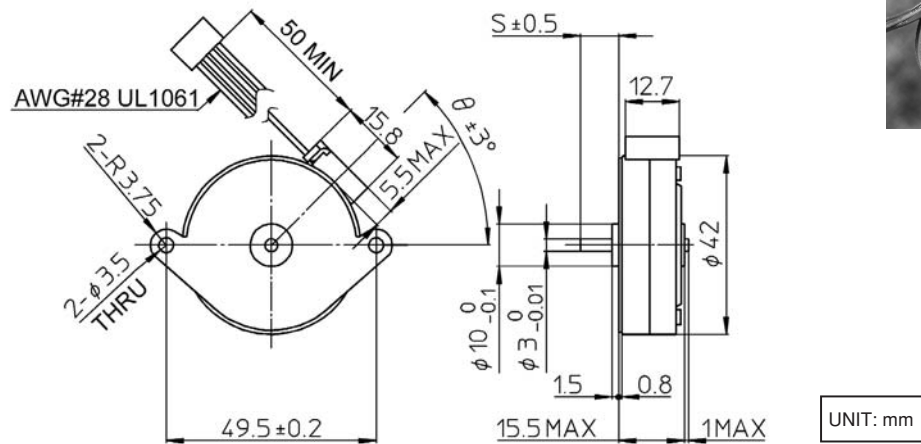

Note: See page 38 for options on mounting holes (H) and lead wire exit angle (θ).

Model Specifications

Reference Characteristics		
Motor Size	PM42S-096	
No. of Steps per Rotation	96 (3.75° / Step)	
Drive Method	2-2 PHASE	
Drive Circuit	UNIPOLAR CONST. VOLT.	BIPOLAR CHOPPER
Drive Voltage	24 [V]	24 [V]
Current / PHASE	500 [mA]	
Coil Resistance / PHASE	90 [Ω]	10 [Ω]
Drive IC	SMDT - 002	UDN2916B-V
Magnet Material	Nd-Fe-B bonded magnet	

Torque/Speed Characteristics

PM42S-096 UNI-CONST. V (at 24 [V], 90 [Ω])

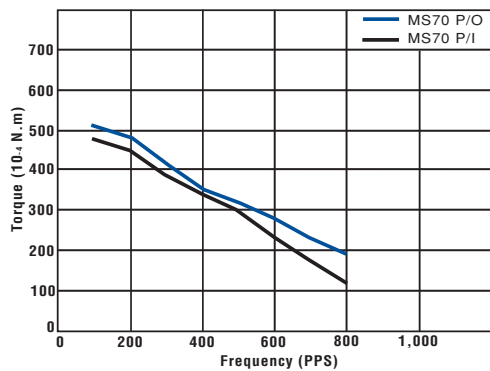

PM42S-096 BI-CHOPPER (at 24 [V], 10 [Ω], 500 [mA])

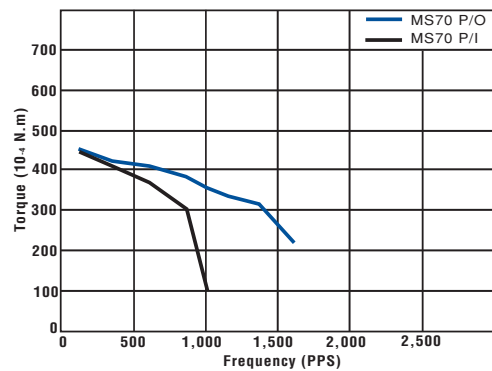

PM42S-100

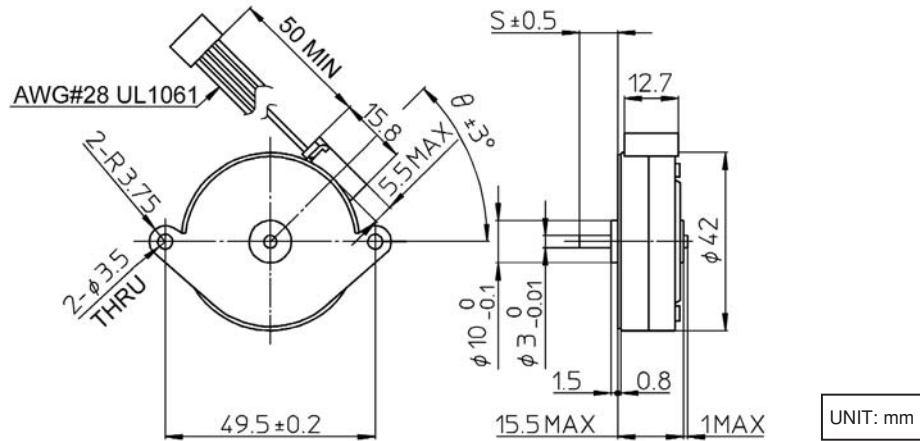

Note: See page 38 for options on mounting holes (H) and lead wire exit angle (θ).

Model Specifications

Reference Characteristics

Motor Size	PM42S-100	
No. of Steps per Rotation	100 (3.6° / Step)	
Drive Method	2-2 PHASE	
Drive Circuit	UNIPOLAR CONST. VOLT.	BIPOLAR CHOPPER
Drive Voltage	12 [V]	24 [V]
Current / PHASE	500 [mA]	
Coil Resistance / PHASE	12 [Ω]	5.8 [Ω]
Drive IC	SMDT - 002	UDN2916B-V
Magnet Material	Nd-Fe-B bonded magnet	

Torque/Speed Characteristics

PM42S-100 UNI-CONST. V (at 12 [V], 12 [Ω])

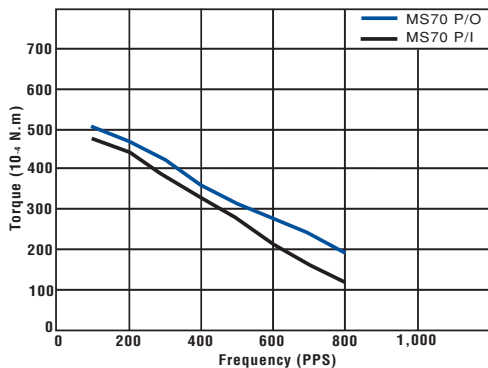

PM42S-100 BI-CHOPPER (at 24 [V], 5.8 [Ω], 500 [mA])

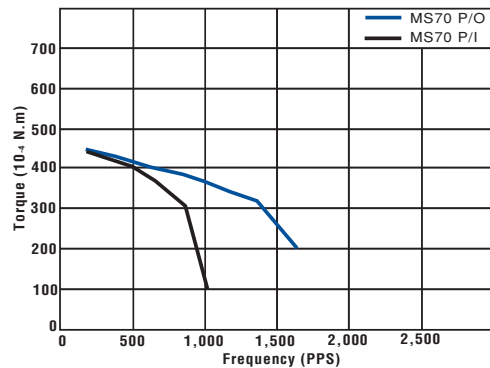

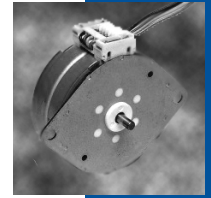
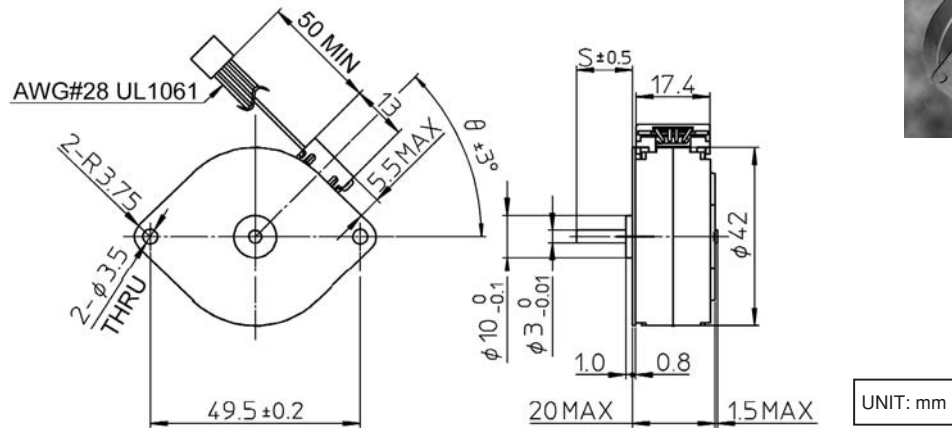

Note: See page 38 for options on mounting holes (H) and lead wire exit angle (θ).

Model Specifications

Reference Characteristics		
Motor Size	PM42M-048	
No. of Steps per Rotation	48 (7.5° / Step)	
Drive Method	2-2 PHASE	
Drive Circuit	UNIPOLAR CONST. VOLT.	BIPOLAR CHOPPER
Drive Voltage	24 [V]	24 [V]
Current / PHASE	500 [mA]	
Coil Resistance / PHASE	80 [Ω]	6 [Ω]
Drive IC	SMDT - 002	UDN2916B-V
Magnet Material	Ferrite plastic magnet, Polar anisotropy ferrite sintered magnet, Nd-Fe-B bonded magnet	

Torque/Speed Characteristics

PM42M-048 UNI-CONST. V (at 24 [V], 80 [Ω])

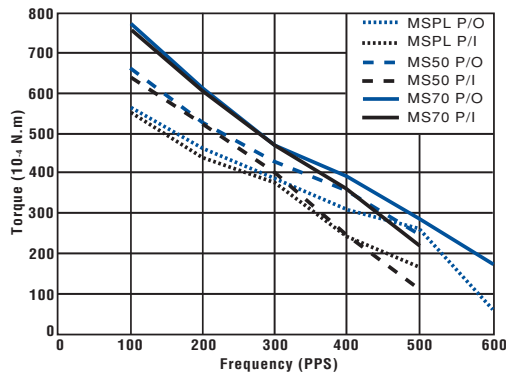

PM42M-048 BI-CHOPPER (at 24 [V], 6 [Ω], 500 [mA])

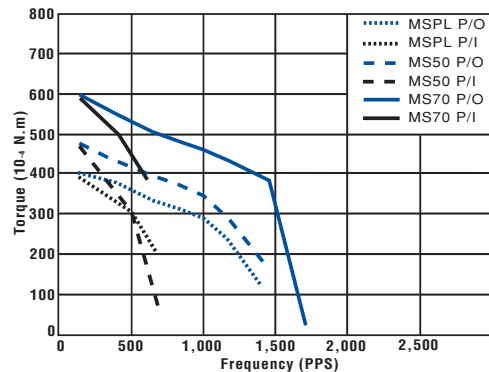

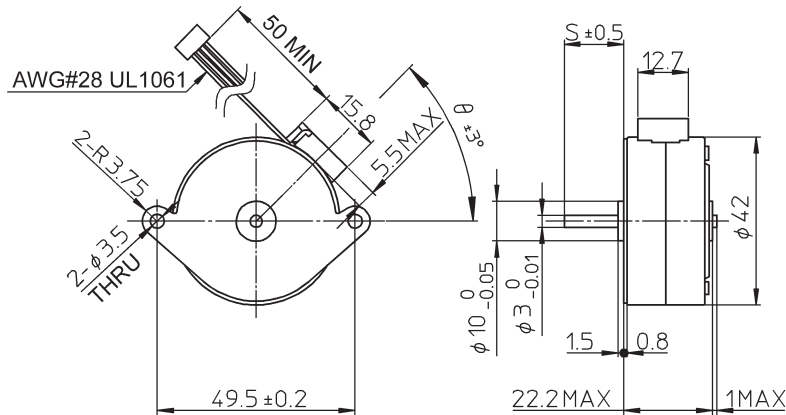

UNIT: mm

Note: See page 38 for options on mounting holes (H) and lead wire exit angle (θ).

Model Specifications

Reference Characteristics

Motor Size	PM42L-048	
No. of Steps per Rotation	48 (7.5° / Step)	
Drive Method	2-2 PHASE	
Drive Circuit	UNIPOLAR CONST. VOLT.	BIPOLAR CHOPPER
Drive Voltage	24 [V]	24 [V]
Current / PHASE	600 [mA]	
Coil Resistance / PHASE	60 [Ω]	7 [Ω]
Drive IC	SMDT - 002	UDN2916B-V
Magnet Material	Ferrite plastic magnet, Polar anisotropy ferrite sintered magnet, Nd-Fe-B bonded magnet	

Torque/Speed Characteristics

PM42L-048 UNI-CONST. V (at 24 [V], 60 [Ω])

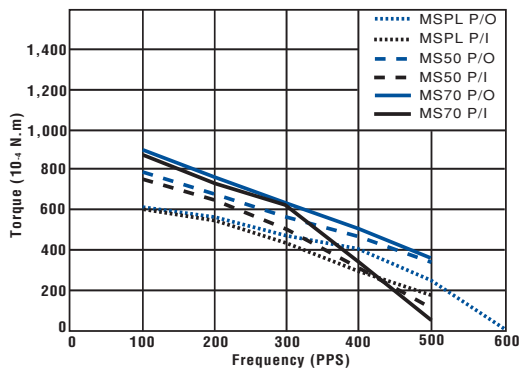

PM42L-048 BI-CHOPPER (at 24 [V], 7 [Ω], 600 [mA])

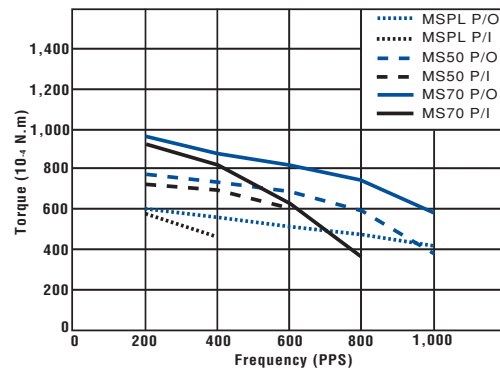

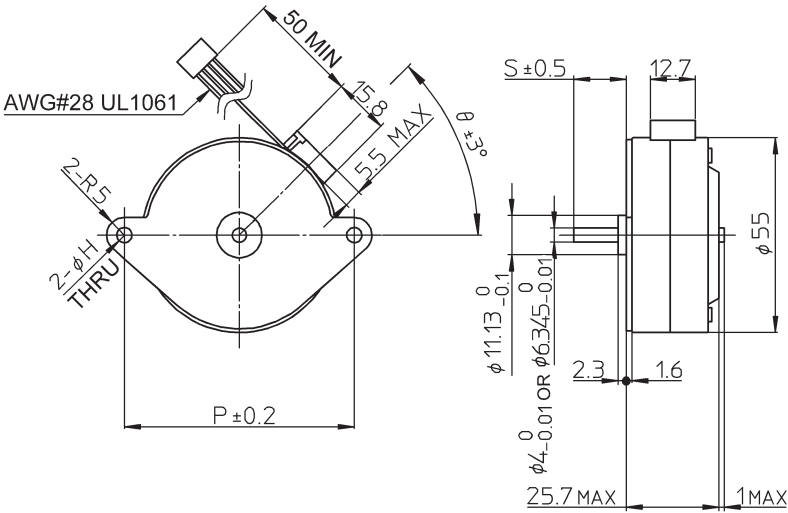

Note: See page 38 for options on pitch (P), mounting holes (H) and lead wire exit angle (θ).

Model Specifications

Reference Characteristics		
Motor Size	PM55L-048	
No. of Steps per Rotation	48 (7.5° / Step)	
Drive Method	2-2 PHASE	
Drive Circuit	UNIPOLAR CONST. VOLT.	BIPOLAR CHOPPER
Drive Voltage	24 [V]	24 [V]
Current / PHASE	600 [mA]	
Coil Resistance / PHASE	30 [Ω]	6 [Ω]
Drive IC	SMDT - 002	UDN2916B-V
Magnet Material	Ferrite plastic magnet, Polar anisotropy ferrite sintered magnet, Nd-Fe-B bonded magnet	

Torque/Speed Characteristics

PM55L-048 UNI-CONST. V (at 24 [V], 30 [Ω])

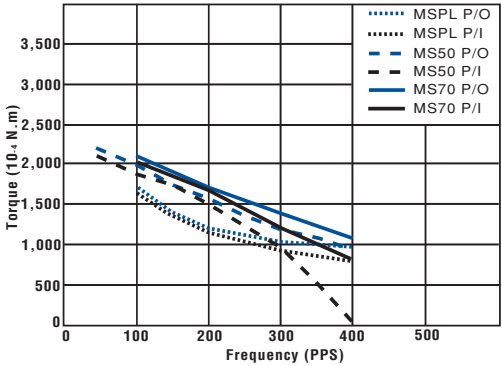

PM55L-048 BI-CHOPPER (at 24 [V], 6 [Ω], 600 [mA])

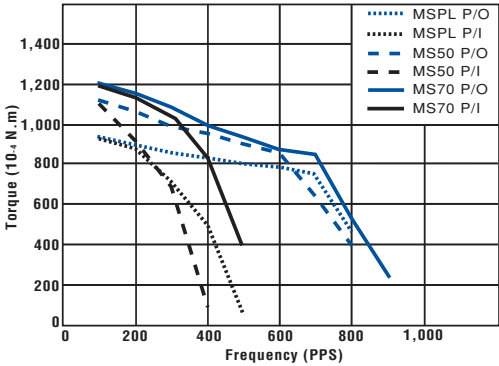

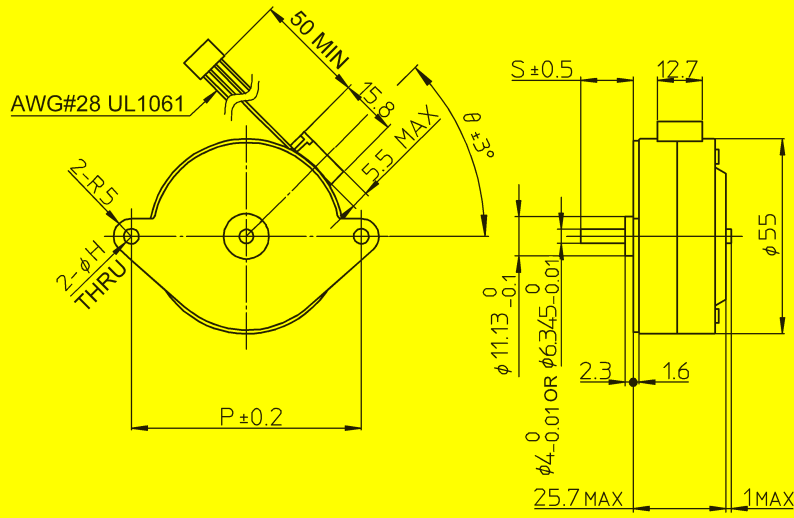

UNIT: mm

Note: See page 38 for options on pitch (p), mounting holes (H) and lead wire exit angle (θ).

Model Specifications

Reference Characteristics

Motor Size	PM55L-096	
No. of Steps per Rotation	96 (3.75° / Step)	
Drive Method	2-2 PHASE	
Drive Circuit	UNIPOLAR CONST. VOLT.	BIPOLAR CHOPPER
Drive Voltage	24 [V]	24 [V]
Current / PHASE	500 [mA]	
Coil Resistance / PHASE	60 [Ω]	7.1 [Ω]
Drive IC	SMDT - 002	UDN2916B-V
Magnet Material	Nd-Fe-B bonded magnet	

Torque/Speed Characteristics

PM55L-096 UNI-CONST. V (at 24 [V], 60 [Ω])

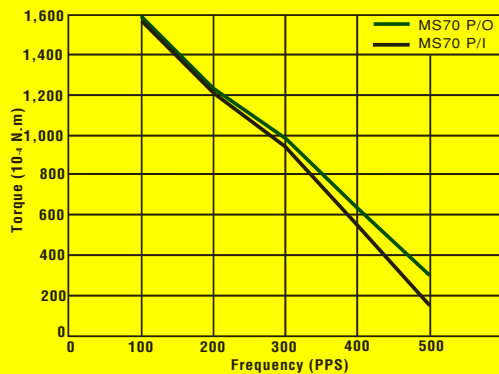

PM55L-096 BI-CHOPPER (at 24 [V], 7.1 [Ω], 500 [mA])

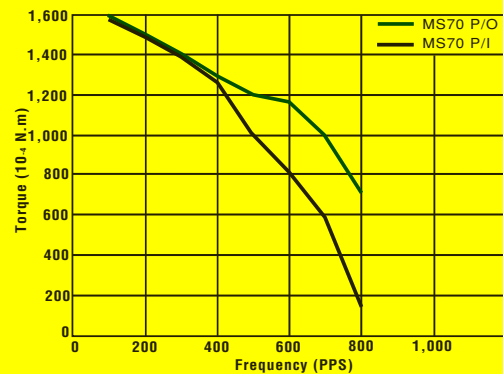

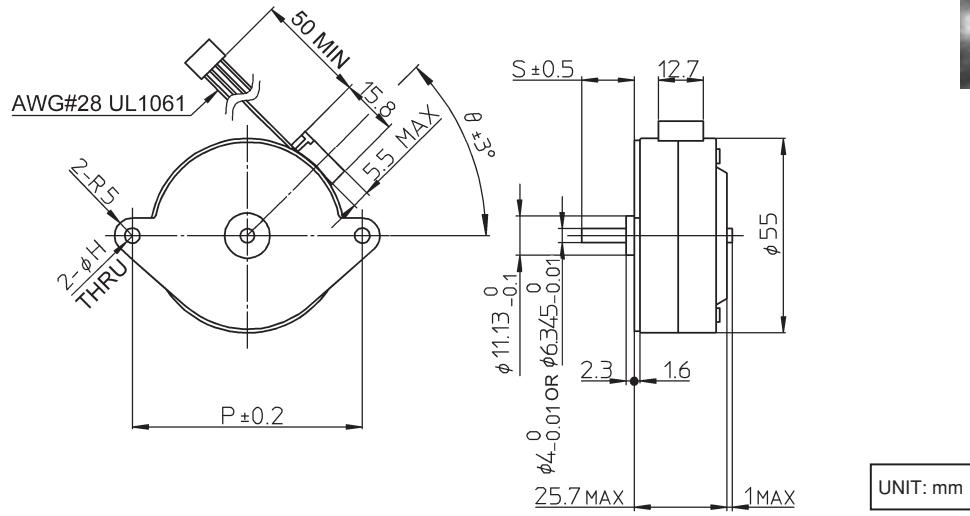

Note: See page 38 for options on pitch (p), mounting holes (H) and lead wire exit angle (θ).

Model Specifications

Reference Characteristics		
Motor Size	PM55L-100	
No. of Steps per Rotation	100 (3.6° / Step)	
Drive Method	2-2 PHASE	
Drive Circuit	UNIPOLAR CONST. VOLT.	BIPOlar CHOPPER
Drive Voltage	24 [V]	24 [V]
Current / PHASE	500 [mA]	
Coil Resistance / PHASE	130 [Ω]	7.1 [Ω]
Drive IC	SMDT - 002	UDN2916B-V
Magnet Material	Nd-Fe-B bonded magnet	

Torque/Speed Characteristics

PM55L-100 UNI-CONST. V (at 24 [V], 130 [Ω])

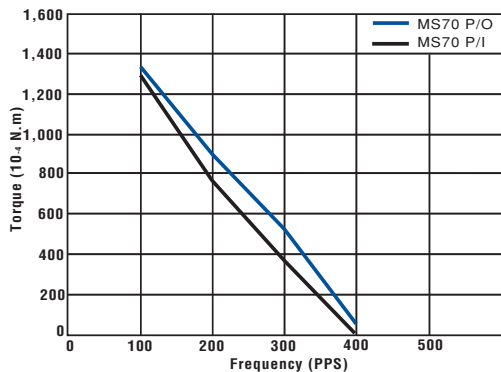

PM55L-100 BI-CHOPPER (at 24 [V], 7.1 [Ω], 500 [mA])

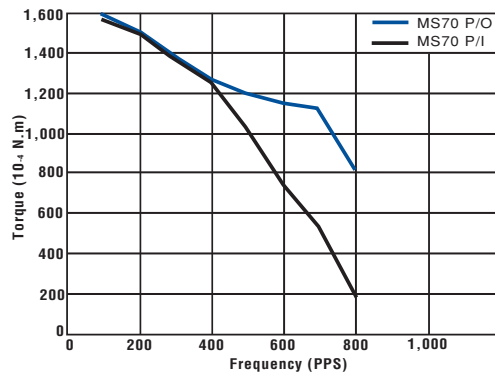

PM20T-036

SPECIAL FOR INSTRUMENTATION

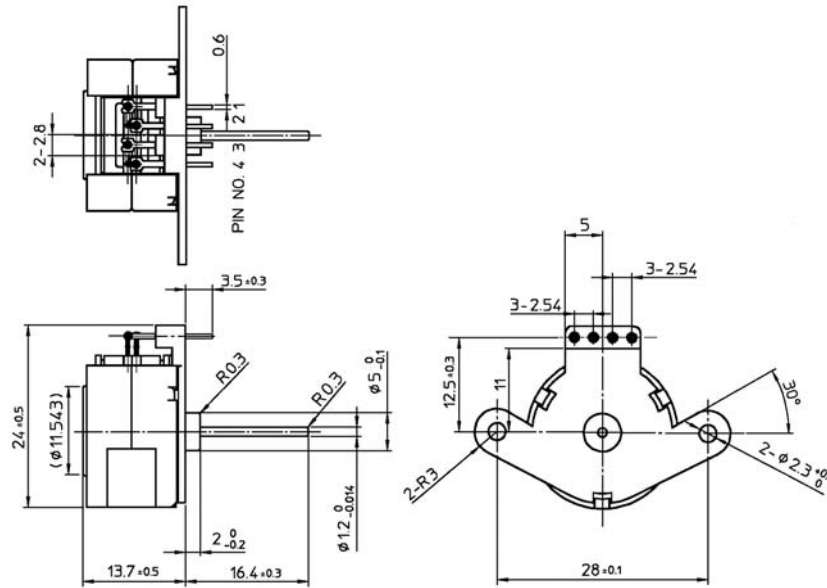

UNIT: mm

Model Specifications

Reference Characteristics

Motor Size	PM20T-036
No. of Steps per Rotation	36 (10° / Step)
Drive Method	Microstep (1/32 ~)
Drive Circuit	Bipolar chopper
Drive Voltage	5 [V]
Current / PHASE	30 [mA]
Coil Resistance / PHASE	180 [Ω]
Magnet Material	Ferrite plastic magnet
Operating Angle	320 [°]
Operating Temp.	-40 ~ +85 [C°]

Torque/Speed Characteristics

PM20T-036 BI-CHOPPER (at 5 [V], 180 [Ω], 30 [mA])

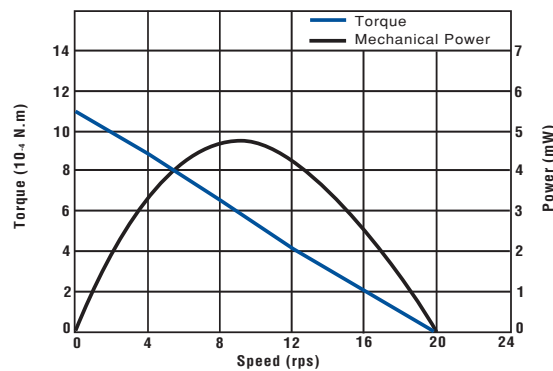

Specification Requirements for Customized Permanent Magnet (PM) and Geared (PG) Motors

NMB can provide custom windings and other features for your PM and PG type motors. The following form will help you gather the specifications that will be required in order to request a customized PM or PG type motor. If you have any questions, or require immediate engineering help, please call motor engineering at 818-341-3355, or e-mail us at motors@nmbtc.com.

Project Information

Customer Name: _____
 Customer PN: _____
 Engineer/Contact: _____
 Phone Number: _____
 Project Name: _____
 Application: _____
 Function: _____
 Target Price: _____
 Production Start: _____
 EAU: _____

Type

Size/step* _____ Gear ratio _____

PM _____
 PG _____

Torque

g-cm @ pps
 oz-in @ rpm
 mN-m

Holding Torque _____
 Detent Torque _____
 Pull Out Torque _____ @ _____
 Pull Out Torque _____ @ _____
 Pull In Torque _____ @ _____

Electrical Specs

Drive Mode: Bipolar Unipolar

Stepping:
 Dual Phase Full Step (2-2) Half Step (1-2)
 Single Phase Full Step (1-1) Microstepping

Drive Type:
 Chopper (Constant current)
 L/R (Constant voltage)

Drive Voltage _____ V
 Drive Current _____ A/phase
 Coil Resistance _____ Ω (If known)
 Which Is Priority Force Resistance

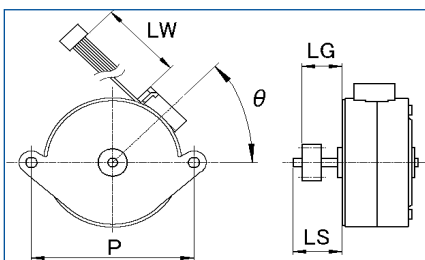

Mechanical Specs

Front Plate Type
 FPH (Through hole)
 FPT (Threaded hole)
 FPL (Slot hole)

Shaft Length (LS); ($LS \geq LG + 0.5$)
 _____ mm in

Rear Shaft
 None (Single shaft)
 Length _____ mm in

Gear/Pulley or D-Cut
 Yes (Customer drawing required)
 No

Gear Position (LG)
 _____ mm in

Lead Wire Exit Angle (θ)
 _____ Degrees (15 degree increments)

Lead Wire Length (LW); (50mm minimum)
 _____ mm in

Connector Direction
 Left (Wire holder - can't use for 25S)
 Right (Wire holder)
 Other (Pin, PCB connector, FPC)

Cable End Connector
 No (Just fly leads)
 Yes (Switching sequence required)
 Maker _____
 Housing PN _____
 Pin PN _____

* For PM55L, choose:
 P 65mm 66.7mm
 Shaft Diameter 4mm 6.345mm