

FEATURES

- Programmable Output Voltage to 40V
- Low Dynamic Output Impedance 0.2Ω
- Sink Current Capability of 0.1 mA to 100 mA
- Equivalent Full-Range Temperature Coefficient of 50 ppm/°C
- Temperature Compensated for Operation over Full Rated Operating Temperature Range
- Low Output Noise Voltage
- Fast Turn on Respons
- TO-92 or SOT-23 and SOT-89 ,SO8packages

PIN CONNECTIONS

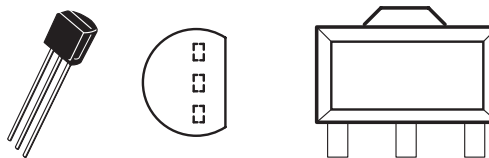

SO8
TL431ACMX

CATHODE	1	8	REF
ANODE	2	7	ANODE
ANODE	3	6	ANODE
NC	4	5	NC



DESCRIPTION

The TL431A is a three-terminal adjustable regulator series with a guaranteed thermal stability over applicable temperature ranges. The output voltage may be set to any value between V_{ref} (approximately 2.5 volts) and 36 volts with two external resistors. These devices have a typical dynamic output impedance of 0.2Ω. Active output circuitry provides a very sharp turn-on characteristic, making these devices excellent replacement for zener diodes in many applications. The TL431A is characterized for operation from -0°C to +70°C.

SYMBOL

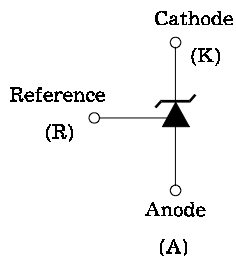

FUNCTIONAL BLOCK DIAGRAM

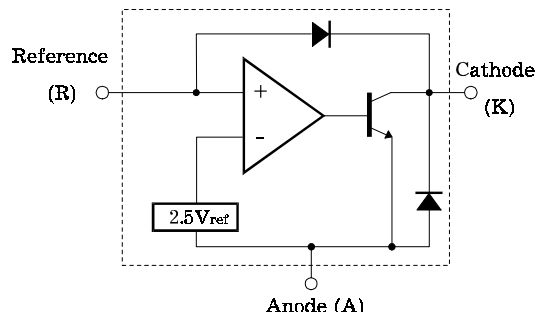

ABSOLUTE MAXIMUM RATINGS

(Operating temperature range applies unless otherwise specified)

Characteristic	Symbol	Value	Unit
Cathode Voltage	V_{KA}	40	V
Cathode Current Range (Continuous)	I_K	100 ~ 150	mA
Reference Input Current Range	I_{REF}	0.05 ~ 10	mA
Power Dissipation at 25°C: TO – 92 Package ($R_{\theta JA} = 178^\circ\text{C/W}$) SOT – 23 – 3 Package ($R_{\theta JA} = 625^\circ\text{C/W}$)	P_D	0.7 0.2	W
Junction Temperature Range	T_J	0 ~ 150	°C
Operating Temperature Range	T_g	0 ~ 70	°C
Storage Temperature Range	T_{stg}	-65 ~ +150	°C

TL431A

Adjustable Precision Shunt Regulator

RECOMMENDED OPERATING CONDITIONS

Characteristic	Symbol	Test Condition	Min	Typ	Max	Unit
Cathode Voltage	V_{KA}		V_{REF}		40	V
Cathode Current	I_K		0.5		100	mA

ELECTRICAL CHARACTERISTICS

($T_a = 25^\circ\text{C}$, $V_{KA} = V_{REF}$, $I_K = 10\text{mA}$ unless otherwise specified)

Characteristic	Symbol	Test Condition	Min	Typ	Max	Unit
Reference Input Voltage	V_{REF}		2.445	2.495	2.545	V
Deviation of Reference Input Voltage Over Full Temperature Range	$V_{REF(dev)}$	$T_{min} \leq T_a \leq T_{max}$		3	17	mV
Ratio of Change in Reference Input Voltage to the Change in Cathode Voltage	$\frac{\Delta V_{REF}}{\Delta V_{KA}}$	$\Delta V_{KA} = 10\text{V} - V_{REF}$ $\Delta V_{KA} = 36\text{V} - 10\text{V}$		-1.4 -1.0	-2.7 -2.0	mV/V
Reference Input Current	I_{REF}	$R_1 = 10\text{K}\Omega$, $R_2 = \infty$		1.8	4	μA
Deviation of Reference Input Current Over Full Temperature Range	$I_{REF(dev)}$	$R_1 = 10\text{K}\Omega$, $R_2 = \infty$		0.4	1.2	μA
Minimum Cathode Current for Regulation	$I_{K(min)}$			0.25	0.5	mA
Off-State Cathode Current	$I_{K(off)}$	$V_{KA} = 40\text{V}$, $V_{REF} = 0$		0.26	0.9	μA
Dynamic Impedance	Z_{KA}	$I_K = 10\text{mA}$ to 100mA , $f \leq 1.0\text{KHz}$		0.22	0.5	Ω

TEST CIRCUITS

Fig.1. Test Circuit for $V_{KA} = V_{REF}$

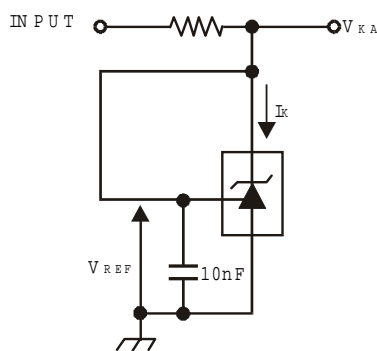

Fig.2. Test Circuit for $V_{KA} \geq V_{REF}$

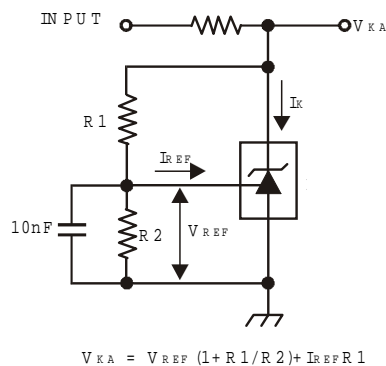
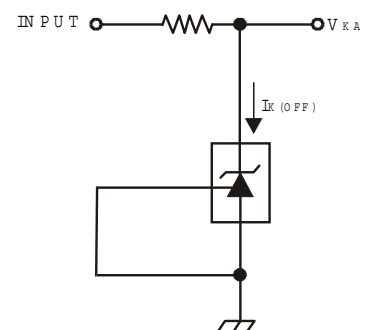

Fig.3. Test Circuit for I_{off}



TL431A

Adjustable Precision Shunt Regulator

PAD LAYOUT

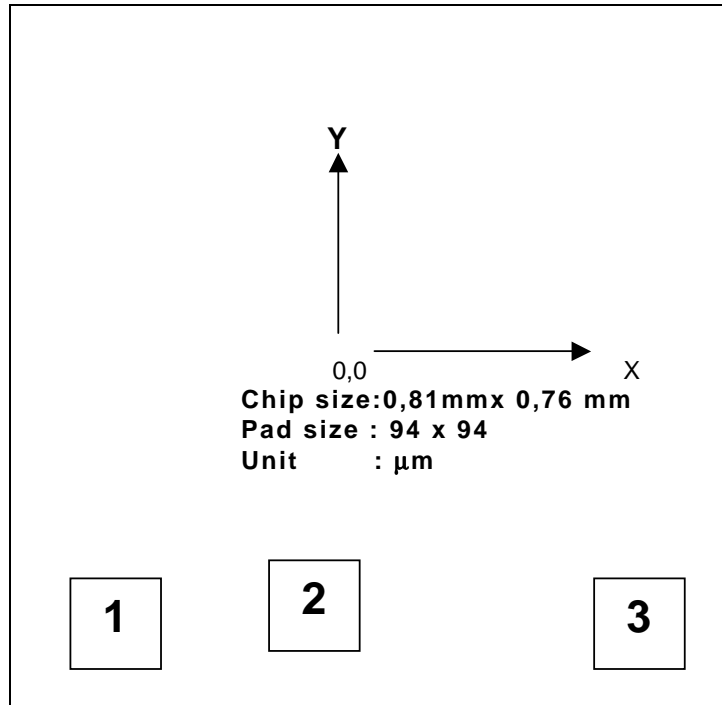

PAD LOCATION

Unit: μm

Pad No.	Pad Name	Description	X	Y
1	R	Reference	-314	-299
2	A	Anode	-75	-275
3	K	Cathode	231	-299

PHYSICAL CHARACTERISTIC

Wafes dia	100 mm (4")
Wafes width	350 \pm 20 μm
Scribe width	90 μm
Passivation	PSG

Ordering Information

Grade	Accuracy	Marking	Min.	Typ.	Max.
AA	\pm 0.5% of Typ.	TL431AA	2.488V	2.495V	2.513V
A	\pm 1 % of Typ.	TL431A	2.475V	2.495V	2.525V
B	\pm 2 % of Typ.	TL431	2.445V	2.495V	2.545V

TO-92 PACKAGE OUTLINE DIMENSIONS

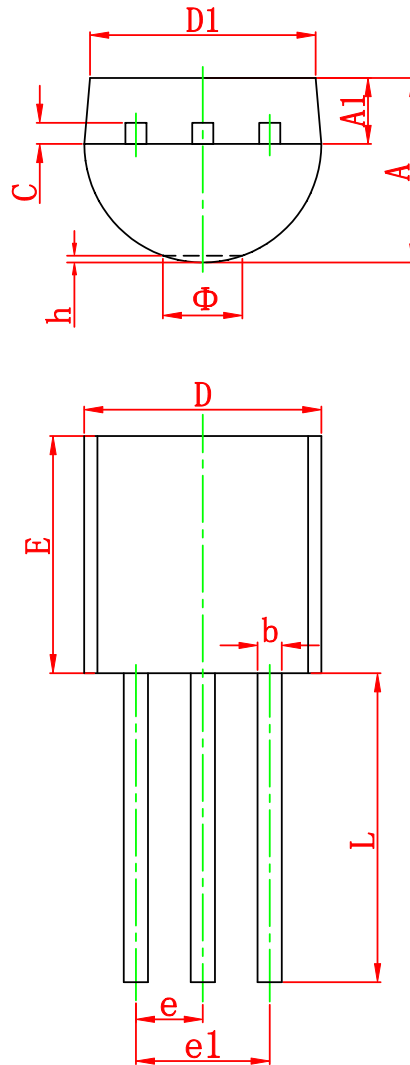

Symbol	Dimensions In Millimeters		Dimensions In Inches	
	Min	Max	Min	Max
A	3.300	3.700	0.130	0.146
A1	1.100	1.400	0.043	0.055
b	0.380	0.550	0.015	0.022
c	0.360	0.510	0.014	0.020
D	4.400	4.700	0.173	0.185
D1	3.430		0.135	
E	4.300	4.700	0.169	0.185
e	1.270 TYP		0.050 TYP	
e1	2.440	2.640	0.096	0.104
L	14.100	14.500	0.555	0.571
Φ		1.600		0.063
h	0.000	0.380	0.000	0.015

SOT-89-3L PACKAGE OUTLINE DIMENSIONS

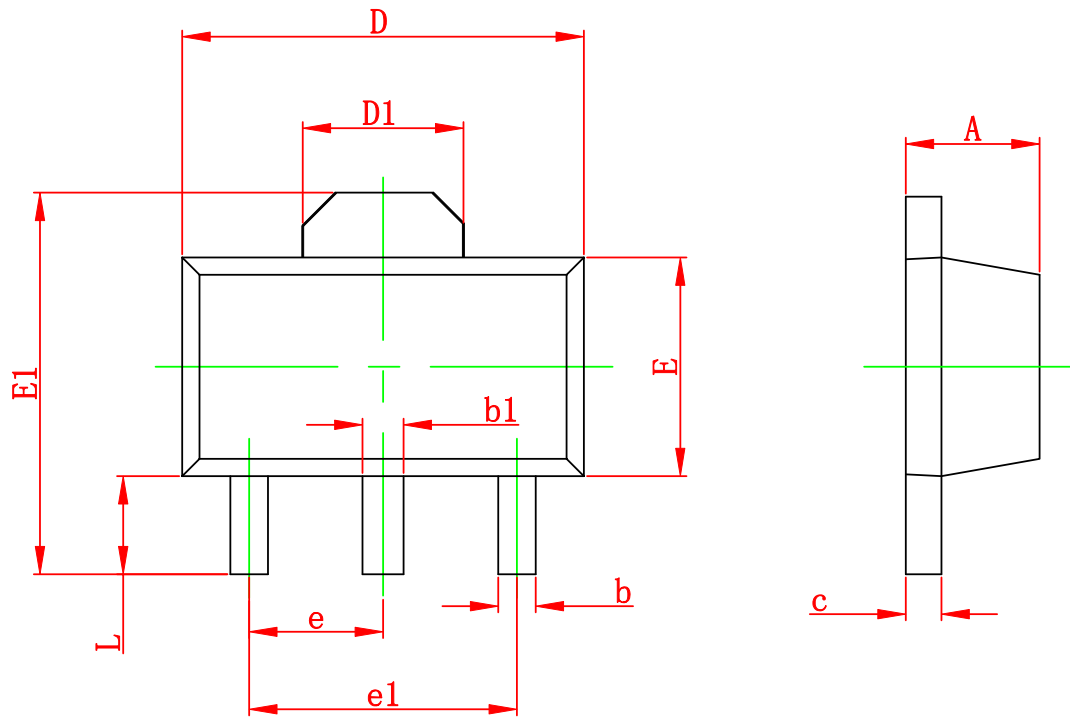

Symbol	Dimensions In Millimeters		Dimensions In Inches	
	Min	Max	Min	Max
A	1.400	1.600	0.055	0.063
b	0.320	0.520	0.013	0.197
b1	0.400	0.580	0.016	0.023
c	0.350	0.440	0.014	0.017
D	4.400	4.600	0.173	0.181
D1	1.550 REF		0.061 REF	
E	2.300	2.600	0.091	0.102
E1	3.940	4.250	0.155	0.167
e	1.500 TYP		0.060TYP	
e1	3.000 TYP		0.118TYP	
L	0.900	1.200	0.035	0.047

SOT-23-3L PACKAGE OUTLINE DIMENSIONS

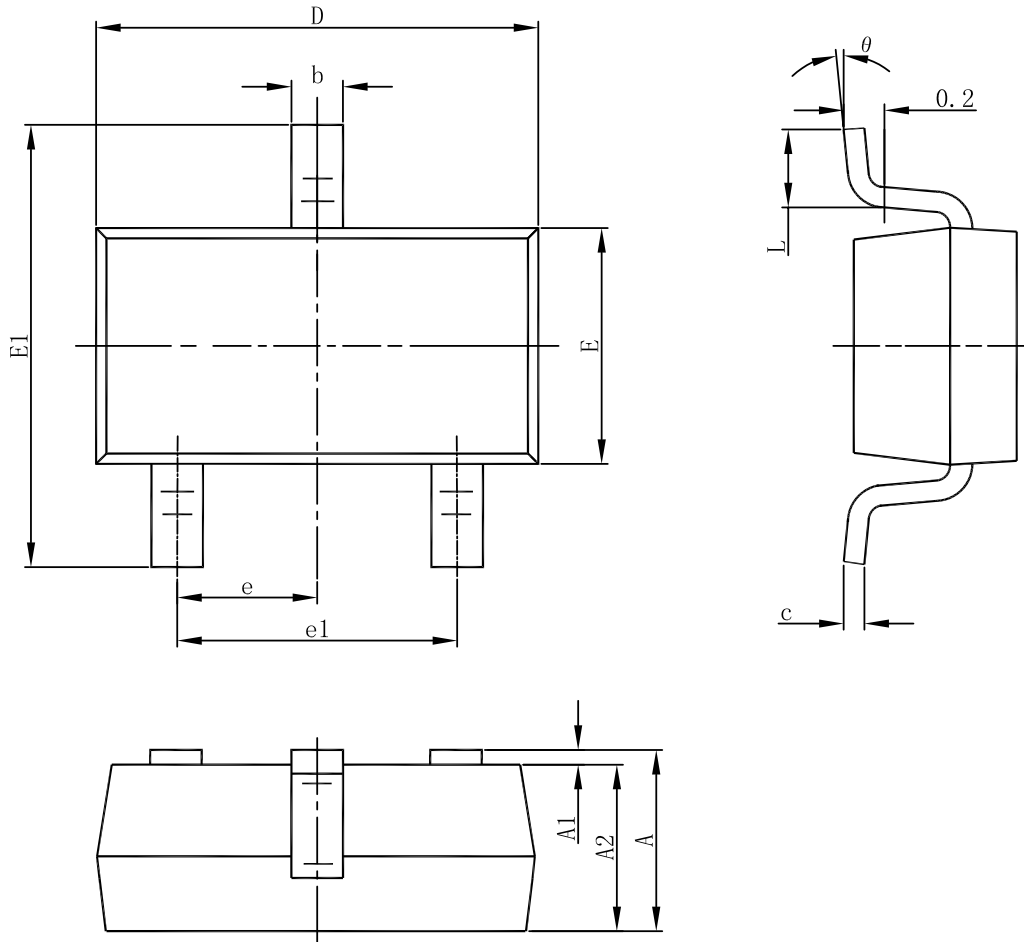

Symbol	Dimensions In Millimeters		Dimensions In Inches	
	Min	Max	Min	Max
A	1.050	1.250	0.041	0.049
A1	0.000	0.100	0.000	0.004
A2	1.050	1.150	0.041	0.045
b	0.300	0.500	0.012	0.020
c	0.100	0.200	0.004	0.008
D	2.820	3.020	0.111	0.119
E	1.500	1.700	0.059	0.067
E1	2.650	2.950	0.104	0.116
e	0.950(BSC)		0.037(BSC)	
e1	1.800	2.000	0.071	0.079
L	0.300	0.600	0.012	0.024
theta	0°	8°	0°	8°

SOP8 PACKAGE OUTLINE DIMENSIONS

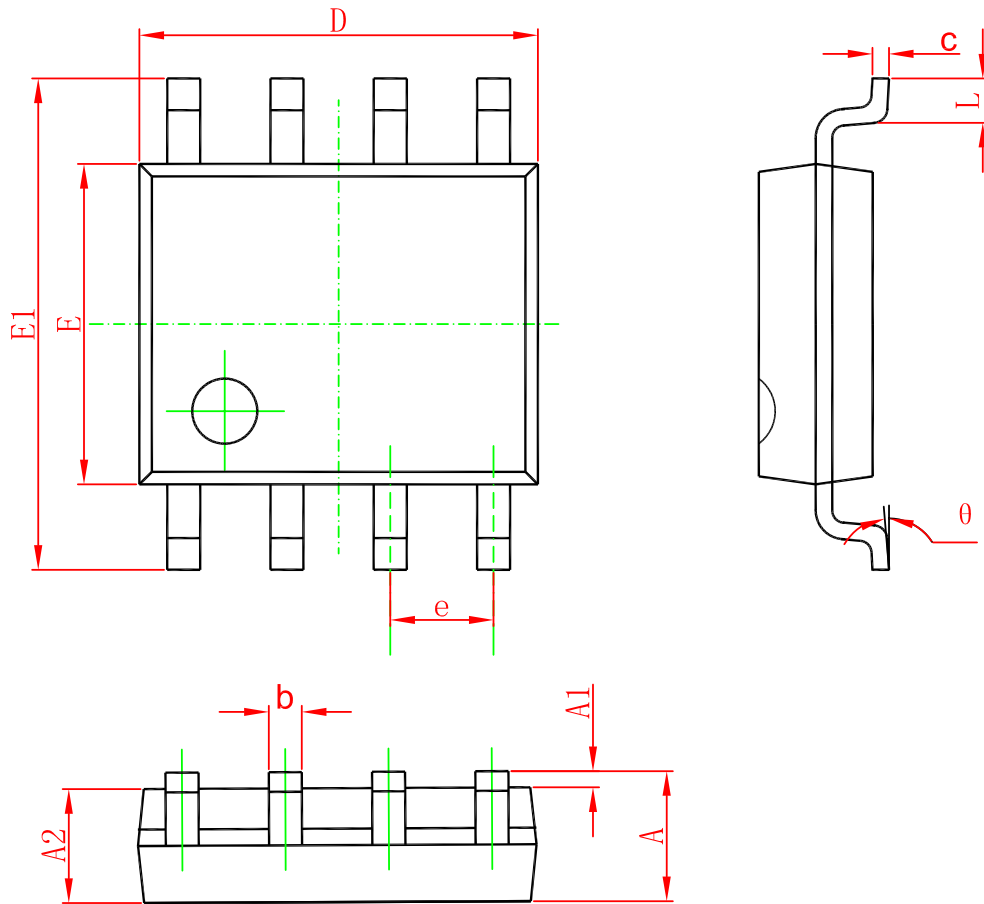

Symbol	Dimensions In Millimeters		Dimensions In Inches	
	Min	Max	Min	Max
A	1.350	1.750	0.053	0.069
A1	0.100	0.250	0.004	0.010
A2	1.350	1.550	0.053	0.061
b	0.330	0.510	0.013	0.020
c	0.170	0.250	0.006	0.010
D	4.700	5.100	0.185	0.200
E	3.800	4.000	0.150	0.157
E1	5.800	6.200	0.228	0.244
e	1.270 (BSC)		0.050 (BSC)	
L	0.400	1.270	0.016	0.050
theta	0°	8°	0°	8°